

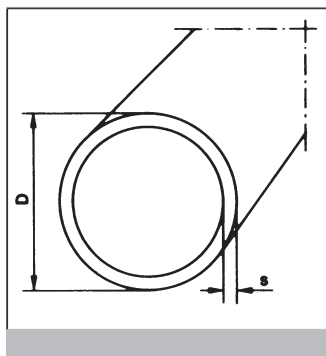

buizen
tuyaux
pipes

PVDF-SOLEF® - HV LINER



DRUKBUIS - HV LINER MET OPPERVLAKTEBEHANDELING
TUYAU DE PRESSION - HV LINER AVEC TRAITEMENT SUR LA SURFACE
PRESSURE PIPE - HV LINER WITH SURFACE TREATED

L = 5 m

da	s	KG/ST/PC	€/M
20	1.9	0.23	52.81
25	1.9	0.29	66.56
32	2.4	0.46	89.18
40	2.4	0.57	110.51
50	3.0	0.89	158.94
63	3.0	1.11	186.92
75	3.0	1.37	230.68
90	2.8	1.65	277.84
110	3.0	2.03	341.83
125	3.0	2.31	388.98
140	3.0	2.60	437.82
160	3.0	2.98	501.80
200	3.0	3.73	628.11
250	3.0	4.68	788.10
315	4.0	7.65	1288.21
355	4.0	9.54	1606.48
400	5.0	12.00	2020.75

HV = chemische etsing waardoor u op het oppervlak een polyester laag kunt aanbrengen.

HV = gravure chimique sur la surface pour adapter une couche en polyester.

HV = chemical etching on the surface so you can add a polyester layer.



stomplasfittings - IR
raccords pour le soudage bout à bout - IR
fittings for butt welding - IR

PVDF-SOLEF® - HV LINER

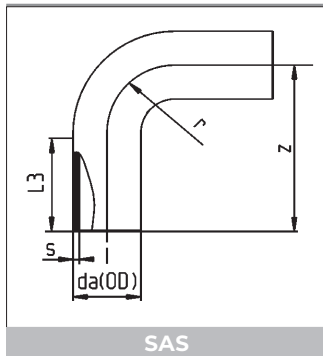

MULTI-BOCHTEN 90°, VERLENGD
MULTI-COUDES 90°, ALLONGES
MULTI-ELBOWS 90°, ELONGATED

Type geschikt voor stomplas / IR + HPF lassen.
Type fait pour soudage bout à bout / IR + HPF.
Type suitable for butt welding / IR + HPF fusion.

D	L3	z	r	s	KG/ST/PC	€/ST/PC
20	33	51	20	1.9	0.021	73.50
25	33	56	25	1.9	0.028	78.38
32	33	63	32	2.4	0.051	85.72
40	36	72	40	2.4	0.076	127.37
50	36	84	50	3.0	0.134	151.86
63	34	97	63	3.0	0.199	193.50
75	28	100	75	3.6	0.297	318.44
90	34	123	90	2.8	0.383	401.70
110	34	142	110	3.4	0.662	543.57

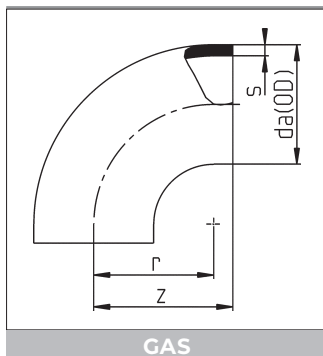

BOCHTEN 90°
COUDES 90°
ELBOWS 90°

Gespoten.
Injectés.
Moulded.

da	r	z	s	KG/ST/PC	€/ST/PC
140	140	148	3.0	0.647	587.86
160	157	181	3.0	0.915	783.81
200	196	217	3.0	1.500	1058.14

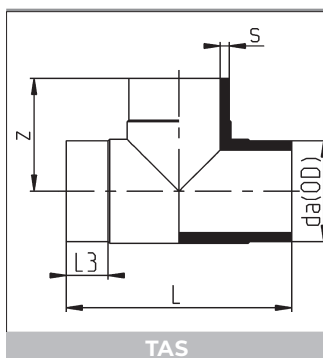

T-STUKKEN 90°, GESPOTEN
TES A 90°, INJECTES
TEES 90°, MOULDED

D	L	L3	z	s	KG/ST/PC	€/ST/PC
20	75	25.0	38	1.9	0.023	99.19
25	84	25.0	42	1.9	0.032	105.80
32	90	25.0	46	2.4	0.060	115.73
40	116	31.0	58	2.4	0.080	171.93
50	126	31.0	64	3.0	0.154	204.99
63	140	31.0	70	3.0	0.230	216.23
75	178	42.0	89	3.6	0.387	429.88
90	185	33.5	92	2.8	0.468	542.30
110	221	33.5	110	5.3	0.868	734.47
140	308	60.0	154	6.7	1.740	793.62
160	279	45.0	140	7.7	1.920	1058.14
200	446	89.0	223	9.6	5.530	1428.49



stomplasmafittings - IR
raccords pour le soudage bout à bout - IR
fittings for butt welding - IR

PVDF-SOLEF® - HV LINER

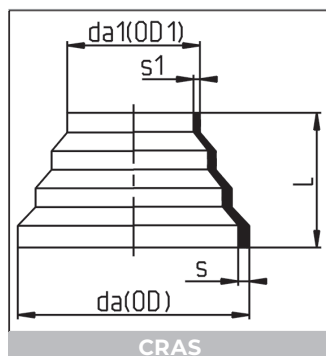

CONCENTRISCHE VERLOOPSTUKKEN
REDUCTIONS CONCENTRIQUES
CONCENTRIC REDUCERS

Gespoten.
Injectés.
Moulded.

da x da1	L	L1	L2	s	s1	KG/ST/PC	€/ST/PC
110 x 63	65	11	7	3.4	2.5	0.127	261.23
160 x 110	85	14	13	4.9	3.4	0.326	734.06