

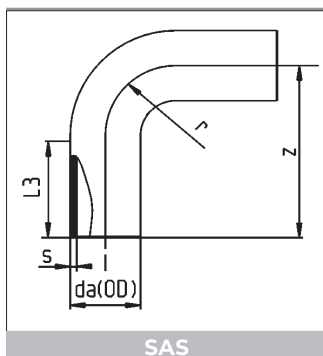

stomplas- en electromoflasfittings - IR
raccords pour le soudage bout à bout et electrosoudable - IR
fittings for butt and electro socket welding - IR

PP-R



MULTI-BOCHTEN 90°
MULTI-COURBES A 90°
MULTI-BENDS 90°

Gespoten.
Injectés.
Moulded.

SDR 17 / ISO S-8

da	L3	r	z	s	KG/ST/PC	€/ST/PC
63	66.5	63	129.5	3.8	0.184	7.70
75	75.0	75	150.0	4.5	0.290	11.28
90	76.0	90	168.0	5.4	0.477	14.70
110	82.0	110	192.0	6.6	0.776	30.99
125	92.0	125	218.0	7.4	1.140	39.33
140	100.0	140	241.0	8.3	1.580	57.16
160	100.5	160	261.5	9.5	2.260	63.05
180	109.0	180	290.5	10.7	3.080	77.94
200	118.5	200	318.5	11.9	4.030	96.53
225	125.0	225	353.0	13.4	5.820	130.88
250	135.0	250	389.0	14.8	7.040	272.71
280	146.0	280	429.0	16.6	9.800	397.39
315	158.0	315	475.0	18.7	14.000	495.39

SDR 11 / ISO S-5

da	L3	r	z	s	KG/ST/PC	€/ST/PC
20	40.0	20	60.0	1.9	0.014	3.32
25	42.5	25	68.5	2.3	0.023	3.46
32	47.0	32	79.0	2.9	0.041	3.58
40	52.0	40	92.5	3.7	0.073	4.63
50	58.5	50	108.5	4.6	0.131	5.82
63	66.5	63	129.5	5.8	0.254	8.36
75	75.0	75	150.0	6.8	0.401	11.53
90	76.0	90	168.0	8.2	0.655	16.69
110	82.0	110	192.0	10.0	1.095	31.77
125	92.0	125	218.0	11.4	1.660	44.77
140	100.0	140	241.0	12.7	2.240	59.86
160	100.5	160	261.5	14.6	3.160	80.25
180	109.0	180	290.5	16.4	4.340	94.99
200	118.5	200	318.5	18.2	5.800	141.54
225	125.0	225	353.0	20.5	8.040	176.49
250	135.0	250	389.0	22.7	10.400	323.01
280	146.0	280	429.0	25.4	14.220	466.76
315	158.0	315	475.0	28.6	19.820	579.78

PPH op aanvraag / sur demande / on request



stomplasmafittings
raccords pour le soudage bout à bout
fittings for butt welding

PP-R

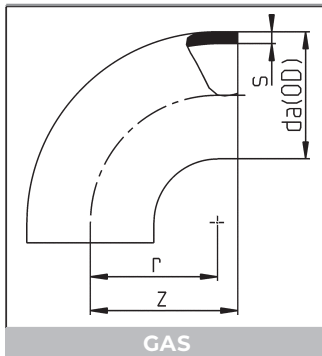

BOCHTEN 90°
COURBES A 90°
BENDS 90°

Gespoten.
Injectés.
Moulded.

SDR 33 / ISO S-16

da	r	z	s	KG/ST/PC	€/ST/PC
110	110	120	3.4	0.252	24.57
125	125	140	3.9	0.333	27.69
140	140	150	4.3	0.461	35.80
160	155	180	4.9	0.740	46.76
180	180	200	5.5	0.999	56.98
200	200	220	6.2	1.320	70.85
225	225	245	6.9	1.810	87.21
250	265	290	7.7	2.740	110.82
280	260	290	8.6	3.600	137.04
315	300	340	9.7	5.000	194.49
355	300	340	10.9	6.360	451.99
400	300	345	12.3	8.120	632.14
450	400	445	13.8	14.180	851.60
500	400	445	15.3	17.560	1186.96

***SDR 17 / ISO S-8**

da	r	z	s	KG/ST/PC	€/ST/PC
250	265	285	14.8	4.96	180.85
280	265	290	16.6	6.20	235.08
315	300	335	18.7	9.42	324.73
355	300	340	21.1	11.60	514.57
400	300	340	23.7	14.48	716.57
450	400	445	26.7	24.24	936.73
500	400	445	29.7	30.32	1286.11

* op aanvraag / sur demand / onrequest : da 20-225 mm

***SDR 11 / ISO S-5**

da	r	z	s	KG/ST/PC	€/ST/PC
250	265	290	22.7	7.44	266.02
280	265	290	25.4	8.92	345.86
315	300	340	28.6	13.54	477.46
355	300	340	32.2	17.36	698.41
400	300	345	36.3	22.00	959.08
450	400	445	40.9	35.56	1258.49
500	400	449	45.4	44.46	1623.46

* op aanvraag / sur demand / onrequest : da 20-225 mm

PPH op aanvraag / sur demande / on request



stomplasmafittingen. gesegmenteerd
raccords pour le soudage bout à bout. segmentés
fittings for butt welding. segmented

PP

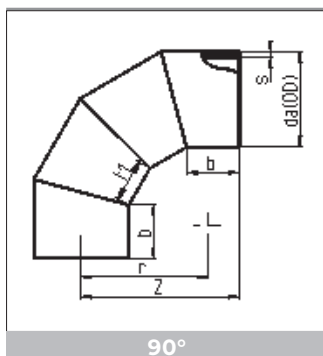

BOCHTEN 90°
COURBES A 90°
BENDS 90°

Veiligheidsfactor x 0.8
Facteur de sécurité x 0.8
Security factor x 0.8

SDR 41 / ISO S-20

da	s	r	b	t1	z	t	t2	KG/ST/PC	€/ST/PC
560	13.7	840	350	300	1040	600	500	36.4	1777.33
630	15.4	945	350	338	1126	675	519	47.6	2133.41
710	17.4	1.065	400	380	1275	761	590	71.6	2603.43
800	19.6	1.200	400	429	1385	857	614	106.0	3143.47
900	22.0	1.350	400	482	1509	965	641	141.0	4198.90
1000	24.5	1.500	500	536	1732	1072	768	180.0	5330.51
1200	29.4	1.800	500	643	1978	1286	822	275.0	7747.51

SDR 33 / ISO S-16

da	s	r	b	t1	z	t	t2	KG/ST/PC	€/ST/PC
560	17.2	840	350	300	1040	600	500	45.3	2123.68
630	19.3	945	350	338	1126	675	519	59.3	2607.48
710	21.8	1.065	400	380	1275	761	590	89.1	3205.78
800	24.5	1.200	400	429	1385	857	614	131.0	3928.63
900	27.6	1.350	400	482	1509	965	641	176.0	5184.90
1000	30.6	1.500	500	536	1732	1072	768	223.0	6547.62
1200	36.7	1.800	500	643	1978	1286	822	341.0	9471.45

SDR 26 / ISO S-12.5

da	s	r	b	t1	z	t	t2	KG/ST/PC	€/ST/PC
560	21.4	840	350	300	1040	600	500	55.8	2611.43
630	24.1	945	350	338	1126	675	519	73.3	3134.98
710	27.2	1065	400	380	1275	761	590	110.0	3831.22
800	30.6	1200	400	429	1385	857	614	162.0	4678.89
900	34.4	1350	400	482	1509	965	641	217.0	6269.99
1000	38.2	1500	500	536	1732	1072	768	275.0	8043.46

SDR 17.6 / ISO S-8.3

da	s	r	b	t1	z	t	t2	KG/ST/PC	€/ST/PC
560	31.7	840	350	300	1040	600	500	81.1	3861.90
630	35.7	945	350	338	1126	675	519	106.0	4691.86
710	40.2	1065	400	380	1275	761	590	159.0	5791.29
800	45.3	1200	400	429	1385	857	614	241.0	7119.60



stomplasmafittingen. gesegmenteerd
raccords pour le soudage bout à bout. segmentés
fittings for butt welding. segmented

PP

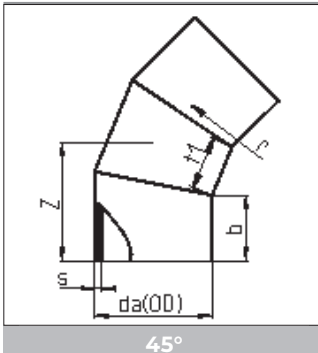

BOCHTEN 45°
COURBES A 45°
BENDS 45°

Veiligheidsfactor x 0.8
Facteur de sécurité x 0.8
Security factor x 0.8

SDR 41 / ISO S-20

da	s	r	b	t1	z	t	t2	KG/ST/PC	€/ST/PC
560	13.7	883	350	223.0	587	445	461	26.4	1178.97
630	15.4	918	350	251.0	616	501	475	34.9	1401.78
710	17.4	1110	400	282.5	700	565	541	53.2	1708.51
800	19.6	1155	400	318.3	738	637	559	70.8	2034.55
900	22.0	1330	400	358.0	780	716	579	99.3	2678.97
1000	24.5	1380	500	398.0	923	796	699	126.0	3428.10
1200	29.4	1480	500	477.5	1007	955	739	188.0	4840.91

SDR 33 / ISO S-16

da	s	r	b	t1	z	t	t2	KG/ST/PC	€/ST/PC
560	17.2	883	350	223.0	587	445	461	32.8	1408.41
630	19.3	918	350	251.0	616	501	475	43.4	1712.83
710	21.8	1110	400	282.5	700	565	541	66.2	2103.49
800	24.5	1155	400	318.3	738	637	559	87.9	2543.31
900	27.6	1330	400	358.0	780	716	579	124.0	3306.71
1000	30.6	1380	500	398.0	923	796	699	156.0	4209.44
1200	36.7	1800	500	477.5	1007	955	739	234.0	5912.83

SDR 26 / ISO S-12.5

da	s	r	b	t1	z	t	t2	KG/ST/PC	€/ST/PC
560	21.4	883	350	223.0	587	445	461	40.4	1731.87
630	24.1	918	350	251.0	616	501	475	53.7	2058.49
710	27.2	1110	400	282.5	700	565	541	81.7	2512.50
800	30.6	1155	400	318.3	738	637	559	109.0	3025.52
900	34.4	1330	400	358.0	780	716	579	153.0	3994.80
1000	38.2	1380	500	398.0	923	796	699	192.0	5169.67

SDR 17.6 / ISO S-8.3

da	s	r	b	t1	z	t	t2	KG/ST/PC	€/ST/PC
560	31.7	883	350	223.0	587	445	461	58.8	2560.87
630	35.7	918	350	251.0	616	501	475	77.9	3080.22
710	40.2	1110	400	282.5	700	565	541	118.0	3797.97
800	47.4	1200	400	318.3	738	637	559	158.0	4604.69



stomplasmafittingen. gesegmenteerd
raccords pour le soudage bout à bout. segmentés
fittings for butt welding. segmented

PP

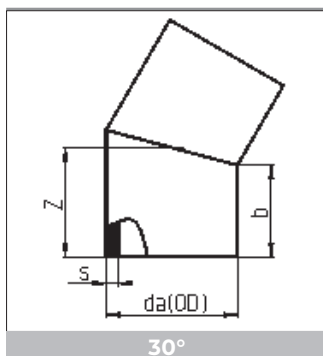

BOCHTEN 30°
COURBES A 30°
BENDS 30°

Veiligheidsfactor x 0.8
Facteur de sécurité x 0.8
Security factor x 0.8

SDR 41 / ISO S-20

da	s	b	z	t	KG/ST/PC	€/ST/PC
560	13.7	350	425	500	18.8	680.44
630	15.4	350	434	519	24.2	812.29
710	17.4	400	495	590	35.9	1016.15
800	19.6	400	507	614	56.0	1214.63
900	22.0	400	521	641	72.1	1598.68
1000	24.5	500	634	768	91.0	2130.18
1200	29.4	500	661	822	136.0	2979.11

SDR 33 / ISO S-16

da	s	b	z	t	KG/ST/PC	€/ST/PC
560	17.2	350	425	500	23.3	817.59
630	19.3	350	434	519	30.1	994.88
710	21.8	400	495	590	44.7	1252.78
800	24.5	400	507	614	69.4	1516.46
900	27.6	400	500	641	90.0	1976.28
1000	30.6	500	634	768	113.0	2620.47
1200	36.7	500	661	822	169.0	3648.38

SDR 26 / ISO S-12.5

da	s	b	z	t	KG/ST/PC	€/ST/PC
560	21.4	350	425	500	28.7	1005.63
630	24.1	350	434	519	37.3	1200.51
710	27.2	400	495	590	55.2	1505.02
800	30.6	400	507	614	86.0	1815.65
900	34.4	400	521	641	215.0	2396.34
1000	38.2	500	634	768	277.0	3223.18

SDR 17.6 / ISO S-8.3

da	s	b	z	t	KG/ST/PC	€/ST/PC
560	31.7	350	425	500	41.7	1491.77
630	35.7	350	434	519	54.1	1799.19
710	40.2	400	495	590	79.9	2274.57
800	47.4	400	507	614	177.0	2760.23



stomplasfittings
raccords pour le soudage bout à bout
fittings for butt welding

PP-R

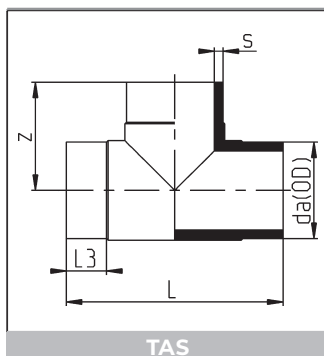

T-STUKKEN 90°
TES A 90°
TEES 90°

Gespoten.
Injectés.
Moulded.

SDR 33 / ISO S-16

da	L	L3	z	s	KG/ST/PC	€/ST/PC
110	223	33	109	3.4	0.443	29.05
125	230	40	115	3.9	0.492	35.52
140	253	25	125	4.3	1.020	39.61
160	346	57	173	4.9	1.680	66.12
180	372	57	186	5.5	2.360	90.13
200	410	57	205	6.2	3.200	120.93
225	448	57	222	6.9	4.260	181.41
250	475	70	237	7.7	6.100	280.53
280	540	80	270	8.6	8.200	356.86
315	558	80	277	9.7	9.640	450.53
355	691	100	346	10.9	16.080	630.85
400	710	104	355	12.3	18.580	924.91
450	900	130	450	13.8	30.740	1248.71
500	895	130	450	15.3	33.660	1621.04

SDR 17 / ISO S-8

da	L	L3	z	s	KG/ST/PC	€/ST/PC
63	145	25.0	72.0	3.8	0.170	7.90
75	150	16.0	75.0	4.5	0.311	16.09
90	212	38.0	107.0	5.4	0.518	22.96
110	251	50.5	121.0	6.6	0.897	38.12
125	280	50.0	140.0	7.4	1.240	52.82
140	304	54.0	150.0	8.3	1.720	62.35
160	346	57.0	173.0	9.5	2.440	117.21
180	372	57.0	186.0	10.7	3.420	143.96
200	405	57.0	202.5	11.9	4.520	196.61
225	445	57.0	222.5	13.4	6.320	230.82
250	470	70.0	235.0	14.8	8.280	306.32
280	543	80.0	272.0	16.6	12.040	346.21
315	550	80.0	275.0	18.7	14.380	460.50
355	680	104.0	340.0	21.1	22.900	692.43
400	705	106.0	352.5	23.7	27.740	946.39
450	895	134.0	450.0	26.7	45.100	1447.66
500	900	130.0	450.0	29.7	51.080	1693.99

PPH op aanvraag / sur demande / on request



stomplasmafittings
raccords pour le soudage bout à bout
fittings for butt welding

PP-R

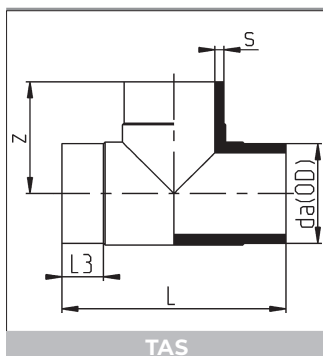

T-STUKKEN 90°

TES A 90°

TEES 90°

Gespoten.
Injectés.
Moulded.

SDR 11 / ISO S-5

da	L	L3	z	s	KG/ST/PC	€/ST/PC
20	68	17.5	34.0	1.9	0.011	2.43
25	80	20.5	40.0	2.3	0.021	2.43
32	90	20.5	45.0	2.9	0.037	3.06
40	100	20.5	50.0	3.7	0.060	4.84
50	120	23.0	60.0	4.6	0.114	6.54
63	144	25.0	72.0	5.8	0.220	10.13
75	152	15.0	75.0	6.8	0.386	20.43
90	213	38.0	105.0	8.2	0.680	30.52
110	253	51.0	122.0	10.0	1.180	44.81
125	280	52.0	140.0	11.4	1.700	61.70
140	305	53.0	152.0	12.7	2.380	78.20
160	346	57.0	173.0	14.6	3.300	131.51
180	372	57.0	186.0	16.4	4.380	168.54
200	405	57.0	202.5	18.2	6.060	241.52
225	445	57.0	222.5	20.5	8.200	287.26
250	470	72.0	235.0	22.7	10.860	365.44
280	540	80.0	270.0	25.4	15.600	494.08
315	550	80.0	275.0	28.6	18.920	702.45
355	690	105.0	345.0	32.2	30.640	902.30
400	700	103.0	355.0	36.3	37.960	1225.97
450	900	130.0	450.0	40.9	63.000	1780.32
500	900	130.0	450.0	45.4	71.000	2274.89

PPH op aanvraag / sur demande / on request



stomplasmafittingen. gesegmenteerd
raccords pour le soudage bout à bout. segmentés
fittings for butt welding. segmented

PP

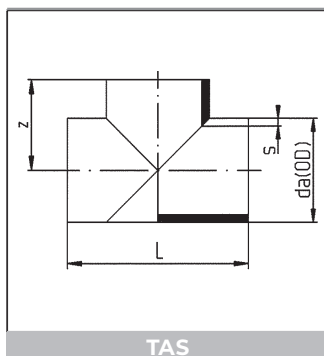

T-STUKKEN 90°

TES A 90°

TEES 90°

Veiligheidsfactor x 0.5

Facteur de sécurité x 0.5

Security factor x 0.5

da	SDR 26 / ISO S-12.5					SDR 17.6 / ISO S-8.3				
	s	z	L	KG ST/PC	€ ST/PC	s	z	L	KG ST/PC	€ ST/PC
560	21.4	540	1080	46.90	2579.60	31.7	540	1080	68.20	3868.59
630	24.1	615	1230	67.80	3195.47	35.7	615	1230	98.40	4829.78
710	27.2	655	1310	90.70	3888.70	40.2	655	1310	131.00	5897.91
800	30.6	700	1400	149.00	4794.50	47.4	700	1400	177.00	7318.61
900	38.2	1000	2000	215.00	7230.74					
1000	30.6	700	1400	277.00	8936.55					



stomplasmafittings
raccords pour le soudage bout à bout
fittings for butt welding

PP-R

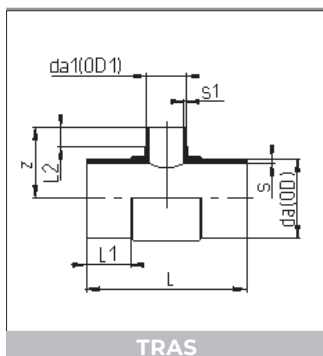

VERLOOP T-STUKKEN 90°
TES REDUITS A 90°
TEES 90° REDUCING

Gespoten.
Injectés.
Moulded.

SDR 17 / ISO S-8

da/da1	s	z	L	L1	L2	s1	KG/ST/PC	€/ST/PC
140/ 63	8.3	120	302	86	32	3.8	1.31	66.35
140/ 75	8.3	130	300	86	35	4.5	1.40	66.64
140/ 90	8.3	139	300	86	42	5.4	1.32	67.76
140/110	8.3	139	300	50	53	6.6	1.64	69.14
160/125	9.5	150	315	62	48	7.4	2.04	128.90
180/ 63	10.7	139	358	130	32	3.8	2.06	153.05
180/ 75	10.7	140	360	120	31	4.5	2.10	153.05
180/110	10.7	160	365	106	48	6.6	2.16	157.74
180/125	10.7	156	365	96	52	7.4	2.24	157.74
225/125	13.4	180	445	140	45	7.4	4.19	250.85

SDR 11 / ISO S-5

da/da1	s	z	L	L1	L2	s1	KG/ST/PC	€/ST/PC
90/ 32	8.2	85	213	57	23	2.9	0.562	32.33
90/ 50	8.2	90	213	57	27	4.6	0.563	33.22
110/ 32	10.0	94	244	70	23	2.9	0.906	48.68
110/ 50	10.0	103	240	70	27	4.6	0.945	48.68
125/ 63	11.4	112	280	76	31	5.8	1.400	68.11
140/ 63	12.7	120	302	87	32	5.8	1.800	85.47
140/ 75	12.7	130	305	54	35	6.8	1.920	85.47
140/ 90	12.7	130	305	88	42	8.2	1.840	86.87
140/110	12.7	141	305	54	47	10.0	2.180	86.87
160/125	14.6	158	335	62	52	11.4	2.720	144.15
180/ 63	16.4	144	367	134	32	5.8	3.040	178.95
180/ 75	16.4	148	366	123	31	6.8	3.100	178.95
180/125	16.4	166	366	100	52	11.4	3.280	184.70
225/125	20.5	178	456	143	45	11.4	6.120	311.57

Grotere diameters t.e.m. 630 mm op aanvraag.
Diamètres plus large jusqu'à 630 mm sur demande.
Larger diameters up to 630 mm on request.

PPH op aanvraag / sur demande / on request



stomplasmafittings
raccords pour le soudage bout à bout
fittings for butt welding

PP-R

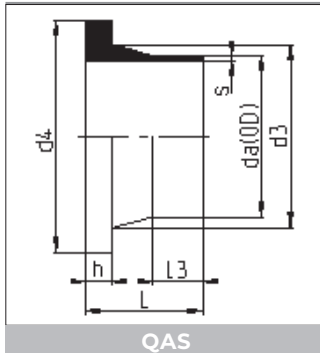

VOORLASKRAGEN
COLLETS
STUBS

Gespoten
Injectés
Moulded

PPH : op aanvraag / sur demande / on request

SDR 33 / ISO S-16

da	s	L	L3	d3	d4	h	KG/ST/PC	€/ST/PC
110	3.4	80	31.0	125	158	18	0.276	12.90
125	3.9	80	38.0	132	158	18	0.282	15.87
140	4.3	80	24.0	155	188	18	0.410	18.41
160	4.9	80	28.5	175	212	18	0.520	22.79
180	5.5	95	55.0	183	212	18	0.450	33.31
200	6.2	113	53.0	232	268	18	1.040	40.93
225	6.9	113	65.0	235	268	18	0.820	44.82
250	7.7	132	70.0	285	320	20	1.730	63.25
280	8.6	128	70.0	288	320	20	1.430	68.23
315	9.7	136	68.0	335	370	20	2.080	81.69
355	10.9	150	75.0	373	430	23	2.920	139.76
400	12.3	155	75.0	427	482	26	3.980	290.32
450	13.8	168	73.0	514	585	33	7.820	339.99
500	15.3	175	81.0	530	585	33	6.960	412.94
560	17.2	120	25.0	615	685	35	8.750	488.63
630	19.3	184	89.0	642	685	35	8.460	562.80

SDR 17 / ISO S-8

da	s	L	L3	d3	d4	h	KG/ST/PC	€/ST/PC
63	3.8	50	20.0	75	102	14	0.107	5.27
75	4.5	50	18.0	89	122	16	0.166	6.21
90	5.4	82	40.0	105	138	17	0.274	9.10
110	6.6	80	34.0	125	158	18	0.359	11.57
125	7.4	84	46.0	132	158	18	0.343	14.23
140	8.3	92	39.0	155	188	18	0.550	16.51
160	9.5	92	42.0	175	212	18	0.696	20.43
180	10.7	92	53.0	183	212	20	0.687	29.85
200	11.9	110	46.0	232	268	24	1.460	37.27
225	13.4	113	60.0	235	268	24	1.380	41.80
250	14.8	132	64.0	285	320	25	2.440	59.72
280	16.6	128	70.0	288	320	25	2.240	65.60
315	18.7	136	68.5	335	370	25	3.140	80.11
355	21.1	150	79.0	373	430	30	4.480	137.27
400	23.7	155	75.0	427	482	33	5.980	277.40
450	26.7	170	74.0	514	585	46	11.340	326.92
500	29.7	175	83.0	530	585	46	10.640	403.03
560	33.2	120	32.0	615	685	50	12.310	482.43
630	37.4	180	122.0	642	685	50	14.720	558.71



stomplasmafittings
raccords pour le soudage bout à bout
fittings for butt welding

PP-R

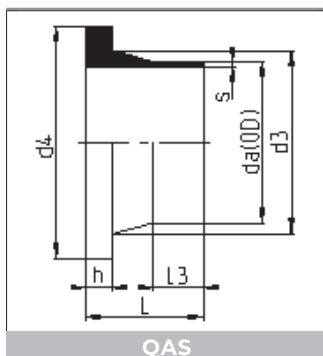

VOORLASKRAGEN
COLLETS
STUBS

Gespoten
Injectés
Moulded

PPH : op aanvraag / sur demande / on request

SDR 11 / ISO S-5

da	s	L	L3	d3	d4	h	KG/ST/PC	€/ST/PC
20	1.9	52.0	30.0	27	45	7	0.014	2.73
25	2.3	52.0	25.0	33	58	9	0.027	2.73
32	2.9	50.0	25.0	40	68	10	0.040	3.21
40	3.7	52.0	24.0	50	78	11	0.061	3.83
50	4.6	53.0	22.0	61	88	12	0.086	4.72
63	5.8	50.0	20.0	75	102	14	0.122	5.87
75	6.8	50.5	18.0	89	122	16	0.187	6.96
90	8.2	82.0	40.0	105	138	17	0.322	9.94
110	10	82.0	38.0	125	158	18	0.442	12.78
125	11.4	82.0	38.0	132	158	25	0.491	15.43
140	12.7	92.0	37.0	155	188	25	0.757	19.79
160	14.6	92.0	38.0	175	212	25	0.956	24.97
180	16.4	93.0	43.0	183	212	30	1.000	35.21
200	18.2	114.0	40.0	232	268	32	2.040	49.68
225	20.5	113.0	52.0	235	268	32	1.960	48.53
250	22.7	130.0	58.0	285	320	35	3.300	82.67
280	25.4	128.0	66.0	288	320	35	3.160	78.83
315	28.6	136.0	65.0	335	370	35	4.600	116.10
355	32.2	150.0	70.0	373	430	40	6.560	164.87
400	36.3	155.0	70.0	427	482	46	8.620	295.24
450	40.9	165.0	62.0	514	585	60	15.360	380.43
500	45.4	175.0	80.0	530	585	60	14.920	438.06
630	57.2	175.0	91.5	642	685	60	20.900	951.57

Ook leverbaar / aussi livrable / also available :

- JIS SDR 11 : da 20-315 mm
- ANSI SDR 11 : da 20-450 mm

Uit plaat gedraaid.
Tournés à partir de plaque.
Turned out of plate.

D	d _s	d _e	L	SDR 33 / ISO S-16			SDR 17 / ISO S-8		
				s	h _i	KG/ST/PC	s	h _i	KG/ST/PC
710	737	800	120	21.8	35	9.8	42.1	50	15.5
800	840	905	120	24.5	36	13.0	47.4	52	20.5
900	944	1005	120	27.6	40	16.3	53.3	55	25.3
1000	1047	1110	140	30.6	42	22.5	59.3	60	35.4
1200	1245	1330	140	36.7	50	33.4			

prijzen op aanvraag / prix sur demande / prices on request



stomplasmafittings
raccords pour le soudage bout à bout
fittings for butt welding

PP-R

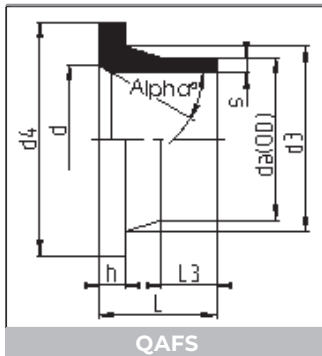

VOORLASKRAGEN VOOR VLINDERKLEPPEN
COLLETS CHANFREINE POUR VANNES PAPILLON
CHAMFERED STUB FLANGE FOR BUTTERFLY VALVES

Gespoten
Injectés
Moulded

SDR 11 / ISO S-5

da	s	L	L3	d	d3	d4	h	Alpha°	KG/ST/PC	€/ST/PC
110	10.0	82	38	100	125	158	18	30	0.420	12.78
140	12.7	92	37	125	155	188	25	30	0.740	19.79
160	14.6	92	38	150	175	212	25	30	0.920	24.97
180	16.4	93	43	150	183	212	30	30	0.997	35.21
200	18.2	114	40	210	232	268	32	30	1.792	49.68
225	20.5	113	52	210	235	268	32	30	1.860	48.53
250	22.7	130	58	255	285	320	35	25	2.866	82.67
280	25.4	128	66	255	288	320	35	25	2.940	78.83
315	28.6	136	65	301	335	370	35	22	4.100	116.09
355	32.2	150	70	338	373	430	40	30	5.960	164.87
400	36.3	155	70	378	427	482	46	30	7.920	295.24

Uit plaat gedraaid.
Tournés à partir de plaque.
Turned out of plate.

SDR 11 / ISO S-5

da	s	L	L3	d	d3	d4	h	Alpha°	KG/ST/PC	€/ST/PC
500	45.4	200	75	505	530	585	90	25	15.400	3008.81

SDR 17 / ISO S-8

da	s	L	L3	d	d3	d4	h	Alpha°	KG/ST/PC	€/ST/PC
355	21.1	150	50	355	373	430	60	25	5.9	1846.61
400	23.7	180	75	404	427	482	60	25	7.4	2057.53
500	29.7	175	80	505	530	585	60	25	10.0	3008.81
560	33.2	200	60	602	615	685	80	25	15.6	3037.86

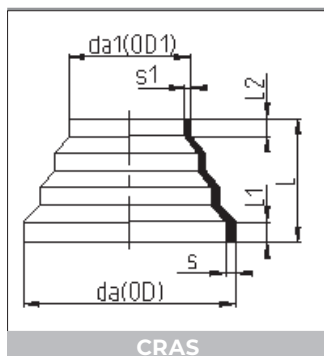
 CONCENTRICHE VERLOOPSTUKKEN
 REDUCTIONS CONCENTRIQUES
 CONCENTRIC REDUCERS
Gespoten.

Opmerkingen :

-Deze verloopstukken zijn voor elke gewenste vermindering tussen de diameters 630 en 16 mm door afzagen. resp. aan elkaar te lassen. te gebruiken.

Injectées.

Remarques :

- Ces réductions sont utilisables dans tous les diamètres. entre 630 et 16 mm. par le sciage et le soudage bout à bout.

Moulded.

Remarks :

- These reductions can be sawn off (or be welded together) at the desired diameter between 630 and 16 mm.

SDR 33 / ISO S-16

da	da1	s	L	L1	L2	s1	KG/ST/PC	€/ST/PC
110	63	3.4	62	9	6	3.0	0.061	12.56
125	75	3.9	72	13	8	2.3	0.090	14.43
160	110	4.9	83	13	13	3.4	0.160	45.61
225	160	6.9	94	18	14	4.9	0.402	115.27
315	225	9.7	134	25	20	6.9	1.036	133.02
450	315	13.8	170	27	20	9.7	3.220	456.00
630	450	19.3	188	30	20	13.8	6.860	563.83

SDR 17 / ISO S-8

da	da1	s	L	L1	L2	s1	KG/ST/PC	€/ST/PC
75	32	4.5	71	10	9	1.9	0.043	10.10
110	63	6.6	62	9	6	3.8	0.099	13.24
125	75	7.4	72	13	8	4.5	0.145	15.07
160	110	9.5	83	13	13	6.6	0.275	49.11
225	160	13.4	94	18	14	9.5	0.660	129.49
315	225	18.7	134	25	20	13.4	1.860	146.88
450	315	26.7	167	27	20	18.7	4.840	504.01
630	450	37.4	188	30	20	26.7	10.60	759.71

SDR 11 / ISO S-5

da	da1	s	L	L1	L2	s1	KG/ST/PC	€/ST/PC
63	16	5.8	97	10	8	1.8	0.042	6.59
75	32	6.8	71	10	9	2.9	0.060	10.53
110	63	10.0	62	9	6	5.8	0.144	13.97
125	75	11.4	72	13	8	6.8	0.200	15.78
160	110	14.6	83	13	13	10.0	0.420	52.59
225	160	20.5	94	18	14	14.6	0.940	142.69
315	225	28.6	134	25	20	20.5	2.720	157.34
450	315	40.9	181	40	20	28.6	7.620	559.87



stomplasmafittings
raccords pour le soudage bout à bout
fittings for butt welding

PP-R

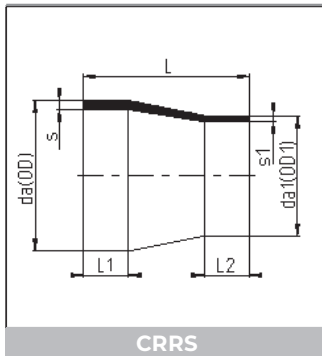

CONCENTRISCHE VERLOOPSTUKKEN
REDUCTIONS CONCENTRIQUES
CONCENTRIC REDUCERS

SDR 17 / ISO S-8

da	da1	s	L	L1	L2	s1	KG/ST/PC	€/ST/PC
75	63	4.5	60	19	18	3.8	0.054	9.28
90	63	5.4	66	22	18	3.8	0.080	10.36
90	75	5.4	66	22	19	4.5	0.097	10.36
110	63	6.6	90	28	18	3.8	0.159	13.13
110	75	6.6	85	28	19	4.5	0.150	13.13
110	90	6.6	85	28	22	5.4	0.159	13.13
125	63	7.4	100	32	18	3.8	0.228	16.94
125	75	7.4	100	32	19	4.5	0.218	16.94
125	90	7.4	90	32	22	5.4	0.186	16.94
125	110	7.4	90	32	28	6.6	0.243	16.94
140	75	8.3	110	35	19	4.5	0.331	20.49
140	90	8.3	110	35	22	5.4	0.290	20.49
140	110	8.3	100	35	28	6.6	0.275	20.49
140	125	8.3	100	35	32	7.4	0.317	23.91
160	90	9.5	115	40	22	5.4	0.400	23.91
160	110	9.5	115	40	28	6.6	0.398	23.91
160	125	9.5	110	40	32	7.4	0.450	23.91
160	140	9.5	110	40	35	8.3	0.460	23.91
180	90	10.7	157	45	22	5.4	0.746	37.60
180	110	10.7	157	45	28	6.6	0.743	35.35
180	125	10.7	122	45	32	7.4	0.560	32.60
180	140	10.7	136	45	35	8.3	0.680	30.94
180	160	10.7	122	45	40	9.5	0.690	29.57
200	140	11.9	137	50	35	8.3	0.840	85.64
200	160	11.9	128	50	40	9.5	0.800	74.82
200	180	11.9	137	50	45	10.7	0.852	66.91
225	140	13.4	162	55	35	8.3	1.121	101.08
225	160	13.4	140	55	40	9.5	0.985	86.74
225	180	13.4	162	55	45	10.7	1.328	86.33
225	200	13.4	162	55	50	11.9	1.300	86.33
250	160	14.8	149	60	40	9.5	1.310	115.80
250	180	14.8	177	60	45	10.7	2.000	107.17
250	200	14.8	144	60	50	11.9	1.380	98.58
250	225	14.8	144	60	55	13.4	1.480	93.74
280	200	16.6	202	70	50	11.9	2.400	128.89
280	225	16.6	202	70	55	13.4	2.400	120.22
280	250	16.6	165	70	60	14.8	2.320	117.09
315	200	18.7	196	80	50	11.9	3.180	164.57
315	225	18.7	207	80	55	13.4	2.940	145.61
315	250	18.7	200	80	60	14.8	2.880	132.64
315	280	18.7	198	80	70	16.6	3.640	124.24

Diam. t.e.m. 630 mm op aanvraag.

Diam. jusqu'à 630 mm sur demande.

Diam up to 630 mm on request.

PPH op aanvraag / sur demande / on request



stomplasmafittings
raccords pour le soudage bout à bout
fittings for butt welding

PP-R

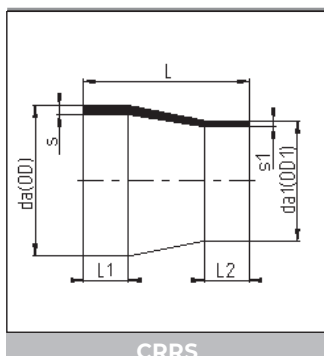

CONCENTRISCHE VERLOOPSTUKKEN
REDUCTIONS CONCENTRIQUES
CONCENTRIC REDUCERS

SDR 11 / ISO S-5

da	da1	s	L	L1	L2	s1	KG/ST/PC	€/ST/PC
25	20	2.3	38	14	14	1.9	0.005	4.51
32	20	2.9	40	14	14	1.9	0.008	5.22
32	25	2.9	40	14	14	2.3	0.009	5.22
40	20	3.7	43	14	14	1.9	0.014	5.96
40	25	3.7	43	14	14	2.3	0.014	5.96
40	32	3.7	37	14	14	2.9	0.013	5.96
50	25	4.6	47	14	14	2.3	0.020	6.27
50	32	4.6	41	14	14	2.9	0.020	6.27
50	40	4.6	42	14	14	3.7	0.022	6.28
63	32	5.8	57	18	14	2.9	0.040	7.59
63	40	5.8	51	18	14	3.7	0.040	7.59
63	50	5.8	52	18	14	4.6	0.044	7.59
75	32	6.8	70	19	14	2.9	0.065	9.73
75	40	6.8	70	19	14	3.7	0.067	9.73
75	50	6.8	59	19	14	4.6	0.066	9.73
75	63	6.8	60	19	18	5.8	0.071	9.73
90	50	8.2	76	22	14	4.6	0.110	10.84
90	63	8.2	66	22	18	5.8	0.108	10.84
90	75	8.2	66	22	19	6.8	0.120	10.84
110	50	10.0	90	28	14	4.6	0.186	13.82
110	63	10.0	90	28	18	5.8	0.197	13.82
110	75	10.0	85	28	19	6.8	0.210	13.82
110	90	10.0	85	28	22	8.2	0.225	13.82
125	63	11.4	100	32	18	5.8	0.275	17.67
125	75	11.4	100	32	19	6.8	0.291	17.67
125	90	11.4	90	32	22	8.2	0.282	17.67
125	110	11.4	90	32	28	10	0.320	17.67
140	75	12.7	110	35	19	6.8	0.383	21.42
140	90	12.7	110	35	22	8.2	0.404	21.42
140	110	12.7	100	35	28	10	0.409	21.42
140	125	12.7	100	35	32	11.4	0.440	21.42
160	90	14.6	115	40	22	8.2	0.550	25.14
160	110	14.6	115	40	28	10	0.585	25.14
160	125	14.6	110	40	32	11.4	0.590	25.14
160	140	14.6	110	40	35	12.7	0.620	25.14
180	90	16.4	157	45	22	8.2	1.000	39.43
180	110	16.4	157	45	28	10	1.000	37.15
180	125	16.4	122	45	32	11.4	0.820	34.22
180	140	16.4	136	45	35	12.8	0.957	32.51
180	160	16.4	122	45	40	14.6	0.905	31.00
200	140	18.2	137	50	35	12.7	1.101	88.86
200	160	18.2	132	50	40	14.6	1.166	78.57
200	180	18.2	137	50	45	16.4	1.310	70.36
225	140	20.5	162	55	35	12.8	1.600	106.08
225	160	20.5	136	55	40	14.6	1.420	91.06
225	180	20.5	162	55	45	16.4	1.920	86.65
225	200	20.5	162	55	50	18.2	1.960	76.42
250	160	22.7	149	60	40	14.6	1.895	121.57
250	180	22.7	177	60	45	16.4	2.420	112.57
250	200	22.7	144	60	50	18.2	2.000	98.59
250	225	22.7	144	60	55	20.5	2.080	103.48
280	200	25.4	188	70	50	18.2	3.440	135.42
280	225	25.4	202	70	55	20.5	3.440	126.26
280	250	25.4	165	70	60	22.7	3.020	121.57
315	200	28.6	200	80	50	18.2	3.860	172.87
315	225	28.6	200	80	55	20.5	4.280	152.91
315	250	28.6	200	80	60	22.7	4.060	139.20
315	280	28.6	227	80	70	25.4	5.125	163.13

Diam. t.e.m. 630 mm op aanvraag.
Diam. jusqu'à 630 mm sur demande.
Diam up to 630 mm on request.

PPH op aanvraag / sur demande /
on request

stomplasmafittings
raccords pour le soudage bout à bout
fittings for butt welding

PP-R

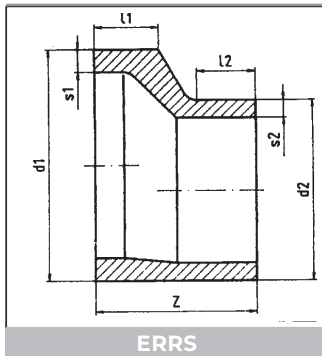

EXCENTRICHE VERLOOPSTUKKEN
REDUCTIONS EXCENTRIQUES
EXCENTRIC REDUCERS

d1	d2	SDR 17			SDR 11		
		s1	s2	z	s1	s2	z
160	90	9.1	5.1	150	14.6	8.2	150
160	110	9.1	6.3	130	14.6	10.0	135
160	125	9.1	7.1	120	14.6	11.4	120
160	140	9.1	8.0	105	14.6	12.8	105
180	110	10.2	6.3	150	16.4	10.0	150
180	125	10.2	7.1	140	16.4	11.4	140
180	140	10.2	8.0	125	16.4	12.8	125
180	160	10.2	9.1	105	16.4	14.6	105
200	125	11.4	7.1	155	18.2	11.4	155
200	140	11.4	8.0	145	18.2	12.8	145
200	160	11.4	9.1	125	18.2	14.6	125
200	180	11.4	10.2	105	18.2	16.4	105
225	140	12.8	8.0	170	20.5	12.8	165
225	160	12.8	9.1	150	20.5	14.6	150
225	180	12.8	10.2	130	20.5	16.4	130
225	200	12.8	11.4	110	20.5	18.2	110
250	160	14.2	9.1	175	22.8	14.6	175
250	180	14.2	10.2	155	22.8	16.4	155
250	200	14.2	11.4	135	22.8	18.2	135
250	225	14.2	12.8	110	22.8	20.5	110
280	180	15.9	10.2	185	25.5	16.4	185
280	200	15.9	11.4	165	25.5	18.2	165
280	225	15.9	12.8	140	25.5	20.5	140
280	250	15.9	14.2	115	25.5	22.8	115
315	200	17.9	11.4	200	28.7	18.2	210
315	225	17.9	12.8	175	28.7	20.5	185
315	250	17.9	14.2	150	28.7	22.8	160
315	280	17.9	15.9	120	28.7	25.5	135
355	225	20.1	12.8	210	32.3	20.5	225
355	250	20.1	14.2	190	32.3	22.8	200
355	280	20.1	15.9	160	32.3	25.5	175
355	315	20.1	17.9	135	32.3	28.7	150
400	250	22.7	14.2	235	36.4	22.8	245
400	280	22.7	15.9	205	36.4	25.5	215
400	315	22.7	17.9	180	36.4	28.7	195
400	355	22.7	20.1	145	36.4	32.3	155
450	280	25.5	15.9	255	41.0	25.5	265
450	315	25.5	17.9	230	41.0	28.7	240
450	355	25.5	20.1	195	41.0	32.3	205
450	400	25.5	22.7	150	41.0	36.4	160
500	315	28.3	17.9	290	45.5	28.7	290
500	355	28.3	20.1	250	45.5	32.3	255
500	400	28.3	22.7	210	45.5	36.4	210
500	450	28.3	25.5	160	45.5	41.0	165
560	400	31.7	22.7	265	51.0	36.4	280
560	450	31.7	25.5	220	51.0	41.0	235
560	500	31.7	28.3	180	51.0	45.5	195
630	450	35.7	25.5	290	57.3	41.0	300
630	500	35.7	28.3	250	57.3	45.5	265
630	560	35.7	31.7	195	57.3	51.0	210
710	560	40.2	31.7	270			
710	630	40.2	35.7	205			
800	560	-	-	360			
800	630	45.3	35.7	290			
800	710	45.3	40.2	225			
900	630	-	-	400			
900	710	51.0	40.2	330			
900	800	51.0	45.3	250			
1000	710	-	-	430			
1000	800	56.6	45.3	345			
1000	900	56.6	51.0	250			

prijzen op aanvraag
prix sur demande
prices on request

stomplasfittings
raccords pour le soudage bout à bout
fittings for butt welding

PP

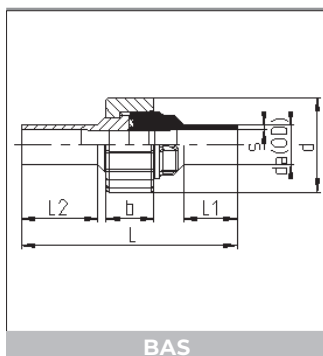

DRIEDELIGE KOPPELINGEN
RACCORDS UNION
UNION SOCKETS

Gespoten SDR 11. ISO S5. O-ring in FPM. moer GVK
Injectés SDR 11. ISO S5. Joint torique en FPM. écrou FRP
Moulded SDR 11. ISO S5. O-ring in FPM. nut FRP

SDR 11 / ISO S-5

da	s	L	L1	L2	d	b	KG/ST/PC	€/ST/PC
20	1.9	108	24.0	38	47	24	0.046	19.96
25	2.3	114	24.0	39	57	26	0.075	21.74
32	2.9	122	25.0	39	64	30	0.106	26.11
40	3.7	128	25.0	42	78	31	0.168	36.91
50	4.6	134	25.0	44	89	35	0.228	52.21
63	5.8	138	25.0	44	109	39	0.382	71.05
*75	6.8	132	28.0	37	130	40	0.593	90.87
*90	8.2	133	35.5	57	130	40	0.609	93.94

* da 75-90 : moer / écrou / nut : PVDF



stomplasmafittings
raccords pour le soudage bout à bout
fittings for butt welding

PP-R

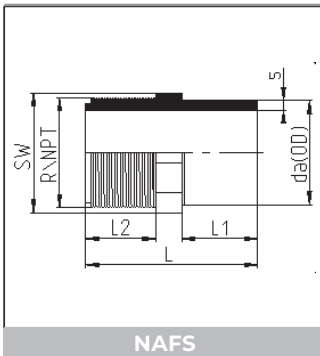

OVERGANGSSTUKKEN
EMBOUITS D'ADAPTATION
ADAPTOR COUPLINGS

Gespoten. S-5/SDR 11

Eén zijde buitendraad (standaard BSP draad. op aanvraag eveneens met NPT draad leverbaar).

Alleen geschikt voor kunststof draadverbindingen.

Injectés. S-5/SDR 11

Un côté mâle (à filetage BSP. également livrables à filetage NPT).

Uniquement pour des connexions matières synthétiques.

Moulded. S-5/SDR 11

One end male threaded (standard thread BSP. also available with NPT thread).

Only for plastic threaded connections.

da	s	L	L1	L2	SW	R	K	E	KG/ST/PC	€/ST/PC
20	1.9	46	20.5	18.0	22	1/2"	18.63	20.96	0.006	5.41
25	2.3	51	22.5	20.0	27	3/4"	24.12	26.44	0.009	6.46
32	2.9	61	29.0	24.0	36	1"	30.29	33.25	0.020	8.17
40	3.7	66	29.0	26.5	46	1 1/4"	38.95	41.91	0.033	9.82
50	4.6	74	33.0	29.0	55	1 1/2"	44.85	47.80	0.054	16.12
63	5.8	80	35.0	32.5	65	2"	56.66	59.61	0.085	20.37

NPT op aanvraag / sur demande / on request

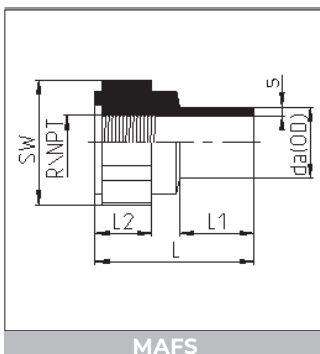

OVERGANGSSTUKKEN
EMBOUITS D'ADAPTATION
ADAPTOR COUPLINGS

Gespoten. S-5/SDR 11.

Eén zijde binnendraad. GVK versterkt.

Alleen geschikt voor kunststof draadverbindingen.

Injectés. S-5/SDR 11.

Un côté femelle. Renforcé fibre de verre.

Uniquement pour des connexions matières synthétiques.

Moulded. S-5/SDR 11.

One end female threaded. Glassfiber reinforced.

Only for plastic threaded connections.

da	s	L	L1	L2	SW	R	K	E	KG/ST/PC	€/ST/PC
20	1.9	45	21	16	32	1/2"	18.63	20.96	0.013	6.87
25	2.3	51	24	18	41	3/4"	24.12	26.44	0.025	7.78
32	2.9	58	30	20	46	1"	30.29	33.25	0.033	10.20
40	3.7	62	30	24	55	1 1/4"	38.95	41.91	0.050	11.67
50	4.6	68	34	25.5	70	1 1/2"	44.85	47.80	0.100	18.38
63	5.8	75	36	30	85	2"	56.66	59.61	0.160	23.01

NPT: op aanvraag / sur demande / on request



stomplas- en electromoflasfittings - IR
 raccords pour le soudage bout à bout et electrosoudable - IR
 fittings for butt and electro socket welding - IR

PP-R

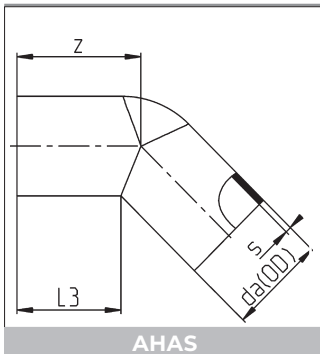

KNIEEN 45°
 COUDES A 45°
 ELBOWS 45°

Met verlengde benen. gespoten. Ook geschikt voor electromoflas.

Coudes injectés. à branches allongées. Convienent aussi pour l'electro-soudage dans l'em-boîture.

Elongated. moulded.. Also suitable for electro socket welding.

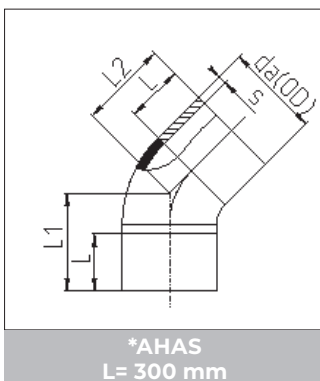

da	*AHAS - SDR 33 / ISO S-16					SDR 17 / ISO S-8					SDR 11 / ISO S-5				
	L2	L1	s	KG ST/PC	€ ST/PC	L3	z	s	KG ST/PC	€ ST/PC	L3	z	s	KG ST/PC	€ ST/PC
20											39.0	44.0	1.9	0.010	2.86
25											42.0	48.0	2.3	0.016	2.96
32											49.0	57.0	2.9	0.033	3.10
40											53.0	63.0	3.7	0.051	3.95
50											57.0	70.0	4.6	0.050	4.99
63						66.0	80.0	3.8	0.110	6.60	67.0	80.0	5.8	0.165	7.16
75						70.0	90.0	4.5	0.175	9.67	72.5	90.0	6.8	0.259	9.87
90						79.0	101.0	5.4	0.291	12.61	82.0	104.0	8.2	0.423	14.30
110	346	356	3.4	0.79	282.33	82.0	112.0	6.6	0.481	26.51	85.0	114.0	10.0	0.668	27.18
125	352	362	3.9	1.09	274.09	99.5	130.5	7.4	0.670	33.67	99.5	132.5	11.4	1.015	38.33
140	358	368	4.3	1.40	306.86	102.0	137.0	8.3	0.847	48.93	100.0	132.5	12.7	1.340	51.25
160	364	389	4.9	1.76	330.00	116.5	156.5	9.5	1.280	53.95	116.5	152.5	14.6	1.980	62.41
180	375	395	5.5	2.24	341.95	133.5	178.5	10.7	1.960	86.54	120.5	158.5	16.4	2.780	96.27
200	383	403	6.2	3.00	354.15	122.5	166.0	11.9	2.150	118.37	120.5	170.5	18.2	3.440	131.52
225	383	403	6.9	3.63	437.02	128.0	184.0	13.4	3.040	141.21	128.0	182.5	20.5	4.660	156.78
250	393	413	7.7	5.00	474.17	160.0	217.0	14.8	4.760	273.24	160.0	217.0	22.7	6.760	303.61
280	408	438	8.6	6.05	530.30	175.0	237.0	16.6	6.200	412.63	173.0	235.0	25.4	8.940	458.47
315	424	464	9.7	8.30	640.81	180.0	251.0	18.7	8.320	513.49	179.0	250.0	28.6	12.260	573.62
						*L2	*L1	*s			*L2	*L1	*s		
355	424	464	10.9	10.40	937.53	424	464	21.1	17.80	1128.20	424	464	32.2	27.40	1583.33
400	424	469	12.3	12.75	1025.27	424	469	23.7	22.70	1411.70	424	469	36.3	34.70	2067.38
450	466	511	13.8	18.10	1258.76	466	511	26.7	31.60	1771.46	466	511	40.9	47.80	2563.53
500						466	511	29.7	39.20	2152.25	466	511	45.4	59.30	3120.20



stompas- en electromoflasfittings - IR
raccords pour le soudage bout à bout et electrosoudable - IR
fittings for butt and electro socket welding - IR

PP-R

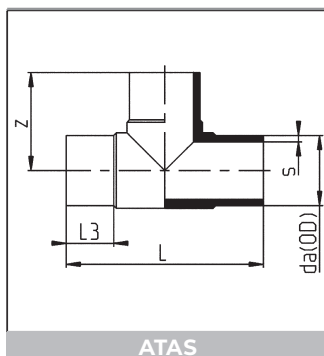

T-STUKKEN 90° VERLENGD
TES A 90° ALLONGES
TEES 90° ELONGATED

Gespoten. Ook geschikt voor electromoflas.
Injectés. Convient aussi pour l'electro-soudage.
Moulded. Also suitable for electric socket welding.

SDR 11 / ISO S-5

da	L3	L	z	s	KG/ST/PC	€/ST/PC
20	37.0	109	57	1.9	0.020	4.70
25	40.0	117	59	2.3	0.034	5.38
32	45.0	144	72	2.9	0.065	6.43
40	51.0	168	84	3.7	0.111	7.96
50	58.0	192	97	4.6	0.188	10.53
63	66.0	229	115	5.8	0.366	14.52
75	71.0	264	131	6.8	0.613	24.09
90	82.0	290	145	8.2	0.954	34.28
110	86.0	320	160	10.0	1.500	50.19
125	93.5	356	175	11.4	2.140	68.87
140	98.0	380	190	12.7	2.760	110.68
160	102.5	410	208	14.6	4.000	143.63
180	138.0	528	264	16.4	6.660	188.45
200	116.0	500	250	18.2	7.740	270.49
225	125.5	552	275	20.5	10.600	320.84
250	148.0	630	315	22.7	14.880	414.28
280	161.0	704	352	25.4	20.320	621.21
315	170.0	760	380	28.6	27.800	795.53



stomplas- en electromoflasfittings - IR
raccords pour le soudage bout à bout et electrosoudable - IR
fittings for butt and electro socket welding - IR

PPR

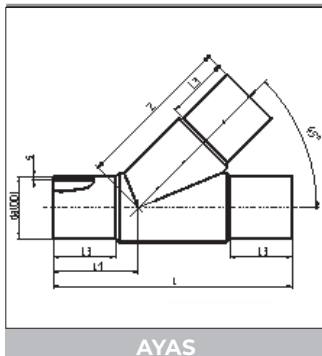

T-STUKKEN 45° VERLENGD
TES A 45° ALLONGES
TEES 45° ELONGATED

Gespoten. Ook geschikt voor electromoflas.
Injectés. Convient aussi pour l'electro-soudage.
Moulded. Also suitable for electric socket welding.

SDR 17 / ISO S-8

da	s	z	L	L3	L1	KG/ST/PC	€/ST/PC
63	3.8	170.0	262	64	93	0.390	48.08
75	4.5	192.0	294	71	103	0.535	78.24
90	5.4	230.0	351	83	122	0.903	108.41
110	6.6	250.5	385	84	131	1.540	159.11
125	7.4	292.5	431	90	140	2.170	218.33
140	8.3	315.5	468	94	150	2.912	350.83
160	9.5	360.0	526	100	166	4.334	455.48
180	10.7	390.0	568	107	179	5.832	597.56
200	11.9	416.0	605	114	191	8.320	857.75
225	13.4	474.0	678	122	206	11.860	1019.51

SDR 11 / ISO S-5

da	s	z	L	L3	L1	KG/ST/PC	€/ST/PC
32	2.9	131.0	195	45	65	0.110	23.43
40	3.7	137.0	211	50	72	0.170	29.08
50	4.6	148.5	228	56	81	0.270	38.55
63	5.8	170.0	262	64	93	0.495	53.12
75	6.8	192.0	294	71	103	0.786	88.13
90	8.2	230.0	351	80	122	1.219	120.77
110	10.0	250.5	385	84	131	2.045	176.80
125	11.4	300.0	431	89	140	2.938	242.67
140	12.7	323.0	467	94	150	3.927	389.97
160	14.6	369.0	530	100	166	5.862	506.04
180	16.4	383.0	568	107	179	7.864	664.00
200	18.2	422.5	605	114	191	10.800	953.55
225	20.5	474.0	678	122	206	15.420	1133.17



stomplas- en electromoflasfittings - IR
raccords pour le soudage bout à bout et electrosoudable - IR
fittings for butt and electro socket welding - IR

PP-R

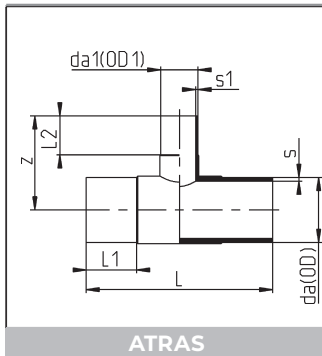

VERLOOP T-STUKKEN 90° VERLENGD
TES REDUITS A 90° ALLONGES
TEES 90° REDUCING ELONGATED

Gespoten. Ook geschikt voor electromoflas.
Injectés. Convient aussi pour l'electro-soudage.
Moulded. Also suitable for electric socket welding.

SDR 17 / ISO S-8

da/ da1	s	z	L	L1	L2	s1	KG/ST/PC	€/ST/PC
63/ 50	3.8	103.0	220	63.0	56.0	3.0	0.208	15.70
75/ 50	4.5	110.0	265	75.0	56.0	3.0	0.406	23.84
75/ 63	4.5	117.0	260	72.0	63.0	3.8	0.415	24.22
90/ 63	5.4	138.5	275	81.0	64.0	3.8	0.591	33.90
90/ 75	5.4	138.0	278	77.0	68.0	4.5	0.570	34.21
110/ 63	6.6	159.0	315	87.0	65.0	3.8	0.957	50.28
110/ 75	6.6	151.0	315	85.0	70.0	4.5	0.850	50.28
110/ 90	6.6	156.0	317	85.0	79.5	5.4	0.915	51.47
125/ 63	7.4	170.0	350	110.0	70.0	3.8	1.380	69.84
125/ 90	7.4	170.0	351	110.0	85.0	5.4	1.300	69.84
125/110	7.4	170.0	340	90.0	83.0	6.6	1.235	69.84
160/ 63	9.5	175.0	347	100.0	67.0	3.8	1.920	138.42
160/ 75	9.5	179.0	348	101.0	76.0	4.5	1.905	142.61
160/ 90	9.5	182.0	349	101.0	80.0	5.4	1.940	142.61
160/110	9.5	202.0	400	100.0	85.0	6.6	2.360	143.93
180/ 90	10.7	202.0	427	138.0	97.0	5.4	2.800	192.41
200/ 63	11.9	225.0	550	134.0	80.0	3.8	4.963	258.69
200/ 90	11.9	229.0	560	134.0	95.0	5.4	5.124	258.69
200/110	11.9	245.0	560	136.0	105.0	6.6	5.220	258.69
200/125	11.9	240.0	550	134.0	110.0	7.4	5.260	258.69
200/160	11.9	275.0	564	137.0	118.0	9.5	6.154	258.57
225/ 75	13.4	226.0	451	120.0	75.0	4.5	4.900	324.67
225/ 90	13.4	226.0	450	120.0	79.0	5.4	5.000	324.67
225/110	13.4	226.0	458	124.0	85.0	6.6	4.960	325.71
225/160	13.4	250.0	505	122.5	100.0	9.5	6.260	326.65
225/180	13.4	280.0	558	135.0	135.0	10.7	7.100	327.22
250/110	14.8	247.0	632	152.0	87.0	6.6	9.980	541.06
250/160	14.8	272.0	630	148.0	101.0	9.5	10.540	541.06
250/200	14.8	294.0	630	148.0	118.5	11.9	11.060	541.06
315/110	18.7	292.0	555	170.0	102.0	6.6	11.400	902.90
315/160	18.7	315.0	585	170.0	120.0	9.5	12.560	902.90
315/225	18.7	335.0	650	170.0	145.0	13.4	13.980	943.91
315/250	18.7	340.0	680	170.0	150.0	14.8	16.200	943.91



stomplas- en electromoflasfittings - IR
raccords pour le soudage bout à bout et electrosoudable - IR
fittings for butt and electro socket welding - IR

PP-R

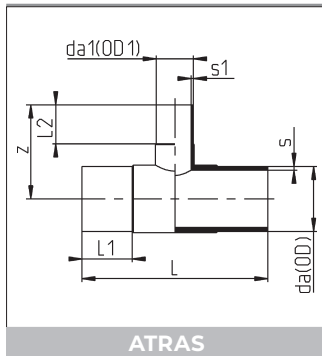

VERLOOP T-STUKKEN 90° VERLENGD
TES REDUITS A 90° ALLONGES
TEES 90° REDUCING ELONGATED

Gespoten. Ook geschikt voor electromoflas.
Injectés. Convient aussi pour l'electro-soudage.
Moulded. Also suitable for electric socket welding.

SDR 11 / ISO S-5

da	s	z	L	L1	L2	s1	KG/ST/PC	€/ST/PC
63/ 25	5.8	85.0	170	65.0	43.0	2.3	0.190	16.99
63/ 32	5.8	103.0	220	63.0	50.0	2.9	0.295	16.99
63/ 50	5.8	103.0	220	63.0	56.0	4.6	0.292	16.99
75/ 32	6.8	107.5	265	75.5	47.0	2.9	0.498	26.61
75/ 50	6.8	110.0	265	75.0	56.0	4.6	0.530	26.61
75/ 63	6.8	117.0	260	72.0	63.0	5.8	0.537	27.17
90/ 63	8.2	138.5	275	81.0	64.0	5.8	0.739	37.94
90/ 75	8.2	140.0	278	77.0	71.0	6.8	0.796	38.21
110/ 63	10.0	159.0	315	87.0	65.0	5.8	1.240	56.23
110/ 75	10.0	151.0	315	85.0	70.0	6.8	1.180	56.23
110/ 90	10.0	156.0	317	85.0	79.5	8.2	1.261	57.01
125/ 90	11.4	170.0	340	112.0	92.0	8.2	1.640	78.24
125/110	11.4	170.0	340	90.0	83.0	10.0	1.850	78.24
160/ 63	14.6	175.0	347	100.0	67.0	5.8	2.560	153.80
160/ 75	14.6	179.0	348	101.0	76.0	6.8	2.620	155.08
160/ 90	14.6	182.0	349	101.0	80.0	8.2	2.620	155.08
160/110	14.6	202.0	400	100.0	85.0	10.0	3.160	158.96
180/ 90	16.4	201.0	427	138.0	97.0	8.2	4.240	213.13
180/110	16.4	225.0	464	148.0	101.0	10.0	4.600	213.13
200/ 63	18.2	226.0	560	135.0	81.0	5.8	6.940	213.13
200/ 90	18.2	230.0	560	137.0	92.0	8.2	6.860	286.78
200/110	18.2	245.0	560	136.0	105.0	10.0	6.980	286.78
200/125	18.2	240.0	560	134.0	110.0	11.4	6.920	286.78
200/160	18.2	275.0	564	137.0	118.0	14.6	8.340	286.78
225/ 75	20.5	226.0	455	124.0	75.0	6.8	6.620	360.40
225/ 90	20.5	226.0	456	124.0	79.0	8.2	6.660	360.40
225/110	20.5	226.0	456	124.0	85.0	10.0	6.660	360.40
225/160	20.5	250.0	498	120.0	100.0	14.6	8.220	361.82
225/180	20.5	280.0	558	135.0	135.0	16.4	9.200	363.11
250/110	22.7	247.0	632	152.0	87.0	10.0	12.460	601.20
250/160	22.7	272.0	634	152.0	101.0	14.6	12.960	601.20
250/200	22.7	294.0	630	148.0	118.5	18.2	14.060	601.20
315/110	28.6	292.0	555	170.0	102.0	10.0	15.680	981.41
315/160	28.6	315.0	585	170.0	120.0	14.6	17.020	981.41
315/225	28.6	335.0	650	170.0	145.0	20.5	20.580	981.41
315/250	28.6	340.0	680	170.0	150.0	22.7	21.840	1025.97



stomplas- en electromoflasfittings - IR
raccords pour le soudage bout à bout et electrosoudable - IR
fittings for butt and electro socket welding - IR

PP-R

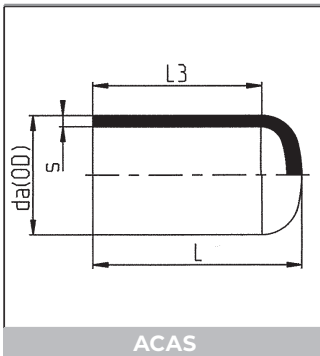

EINDKAPPEN VERLENGD
BOUCHONS ALLONGES
END CAPS ELONGATED

SDR 11

Gespoten. Ook geschikt voor electromoflas.
Injectés. Convient aussi pour l'électro-soudage.
Moulded. Also suitable for electric socket welding.

ISO S-5/SDR 11

da	L3	L	S	KG/ST/PC	€/ST/PC
20	41.0	47	1.9	0.006	3.65
25	41.0	49	2.3	0.008	4.03
32	47.0	56	2.9	0.016	5.06
40	51.0	64	3.7	0.027	6.25
50	60.0	73	4.6	0.048	8.17
63	68.0	84	5.8	0.088	10.77
75	75.0	93	6.8	0.140	16.68
90	84.0	109	8.2	0.240	25.33
110	104.0	136	10.0	0.457	34.32
125	102.0	138	11.4	0.565	37.09
140	106.0	144	12.7	0.788	46.39
160	118.5	170	14.6	1.140	52.00
180	115.0	164	16.4	1.420	67.59
200	127.0	181	18.2	1.880	84.21
225	131.0	202	20.5	2.680	100.50
250	161.0	230	22.7	3.760	150.62
280	162.0	257	25.4	5.240	213.92
315	171.0	272	28.6	6.870	287.62



stomplas- en electromoflasfittings - IR
raccords pour le soudage bout à bout et électrosoudable - IR
fittings for butt and electro socket welding - IR

PP-R

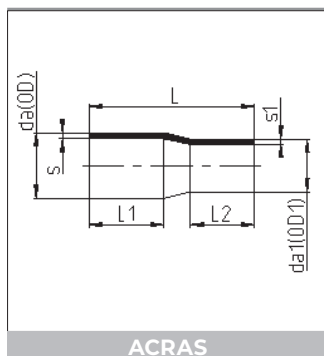

CONCENTRICHE VERLOOPSTUKKEN VERLENGD
REDUCTIONS CONCENTRIQUES ALLONGEES
CONCENTRIC REDUCERS ELONGATED

L = 5 m. gladde uitvoering

Gespoten. Ook geschikt voor electromoflas.
Injectées. Convient également pour l'électrosoudage.
Moulded. Also suitable for electro socket welding.

SDR 11 / ISO S-5

da	da1	L	L1	L2	s	s1	KG/ST/PC	€/ST/PC
25	20	87	40	41	2.3	1.9	0.012	3.13
32	20	92	43	39	2.9	1.9	0.017	3.48
32	25	92	44	39	2.9	2.3	0.020	3.48
40	20	102	48	39	3.7	1.9	0.028	5.06
40	25	102	48	39	3.7	2.3	0.034	5.06
40	32	104	48	45	3.7	2.9	0.037	5.06
50	25	118	55	44	4.6	2.3	0.051	6.27
50	32	118	59	46	4.6	2.9	0.040	6.27
50	40	126	57	50	4.6	3.7	0.068	6.27
63	25	138	65	44	5.8	2.3	0.090	8.31
63	32	136	64	49	5.8	2.9	0.097	8.31
63	40	128	59	50	5.8	3.7	0.099	8.31
63	50	150	66	59	5.8	4.6	0.128	8.31
75	50	148	64	58	6.8	4.6	0.159	12.89
75	63	149	65	64	6.8	5.8	0.183	12.89
90	63	157	72	60	8.2	5.8	0.250	18.04
90	75	163	75	63	8.2	6.8	0.282	18.17
110	63	180	83	63	10.0	5.8	0.405	24.25
110	90	180	83	75	10.0	8.2	0.484	24.25
125	63	187	87	61	11.4	5.8	0.532	29.21
125	90	190	92	75	11.4	8.2	0.608	29.21
125	110	200	89	82	11.4	10.0	0.697	29.21
140	125	215	95	95	12.7	11.4	0.940	41.94
160	90	220	99	85	14.6	8.2	1.000	55.98
160	110	220	99	88	14.6	10.0	1.120	56.14
160	125	228	98	92	14.6	11.4	1.280	56.14
160	140	229	101	96	14.6	12.7	1.300	56.47
180	125	272	131	96	16.4	11.4	1.790	72.75
180	160	245	110	108	16.4	14.6	2.000	72.75
200	160	252	112	102	18.2	14.6	2.140	79.73
225	160	270	128	101	20.5	14.6	2.800	128.26
250	160	317	155	113	22.7	14.6	3.880	173.41
250	200	314	155	125	22.7	18.2	4.200	181.38
250	225	315	153	133	22.7	20.5	4.540	181.38
280	250	355	165	155	25.4	22.7	6.220	241.73
315	200	380	180	134	28.6	18.2	7.120	311.02
315	250	375	170	155	28.6	22.7	7.760	311.02



stomplas- en electromoflasfittings - IR
raccords pour le soudage bout à bout et électrosoudable - IR
fittings for butt and electro socket welding - IR

PP-R

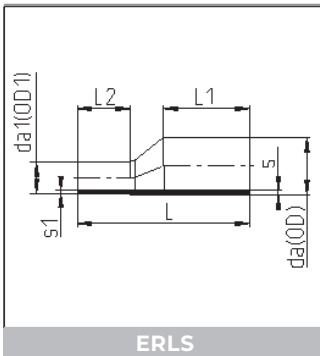

EXCENTRICHE VERLOOPSTUKKEN VERLENGD
REDUCTIONS EXCENTRIQUES ALLONGEES
EXCENTRIC REDUCERS ELONGATED

Gespoten. Ook geschikt voor electromoflas.
Injectées. Convient également pour l'électrosoudage.
Moulded. Also suitable for electro socket welding.

SDR 11 / ISO S-5

da/da'	L	L1	L2	s	s1	KG/ST/PC	€/ST/PC
25/ 20	103.0	51.0	38.0	2.3	1.9	0.018	3.71
32/ 25	114.0	56.0	40.0	3.0	2.3	0.020	4.35
40/ 25	126.0	60.0	40.0	3.7	2.3	0.046	5.93
40/ 32	125.0	59.0	44.0	3.7	3.0	0.045	5.93
50/ 32	156.0	71.0	45.0	4.6	2.9	0.082	7.41
50/ 40	157.0	71.0	49.0	4.6	3.7	0.085	7.41
63/ 32	177.0	75.0	45.0	5.8	2.9	0.127	10.65
63/ 40	177.0	76.0	49.0	5.8	3.7	0.130	10.65
63/ 50	177.0	76.0	56.0	5.8	4.6	0.149	10.65
75/ 50	197.0	84.0	57.0	6.8	4.6	0.216	16.45
75/ 63	197.0	83.0	63.0	6.8	5.8	0.243	16.45
90/ 63	220.0	92.0	64.0	8.2	5.8	0.345	23.05
90/ 75	223.0	97.0	70.0	8.2	6.8	0.390	23.05
110/ 63	247.0	99.0	63.0	10.0	5.8	0.550	31.05
110/ 90	244.0	98.0	79.0	10.0	8.2	0.629	31.05
125/ 63	268.0	105.0	63.0	11.4	5.8	0.785	37.23
125/ 90	265.0	106.5	79.0	11.4	8.2	0.856	37.23
125/110	265.0	103.0	87.0	11.4	10.0	0.927	37.23
140/125	287.0	113.5	94.0	12.7	11.4	1.265	53.63
160/ 90	309.0	117.5	79.0	14.6	8.2	1.480	71.59
160/110	309.0	115.5	87.0	14.6	10.0	1.560	71.59
160/125	309.0	116.5	91.0	14.6	11.4	1.658	71.59
160/140	308.0	116.5	98.0	14.6	12.7	1.760	71.59
180/ 90	348.0	128.5	79.0	16.4	8.2	2.120	93.06
180/125	353.0	135.5	93.0	16.4	11.4	2.380	93.06
180/160	353.0	135.5	104.0	16.4	14.6	2.680	93.06
200/160	373.0	138.5	104.0	18.2	14.6	3.200	101.97
200/180	373.0	143.5	111.0	18.2	16.4	3.410	101.97
225/160	405.0	154.5	102.5	20.5	14.6	4.200	164.02
225/180	403.0	154.5	111.0	20.5	16.4	4.440	164.02
225/200	403.0	155.5	126.0	20.5	18.2	4.623	164.02
250/200	440.5	180.0	120.0	22.7	18.2	6.020	215.27
250/225	442.0	182.0	125.0	22.7	20.5	6.336	215.27



stomplas- en electromoflasfittings - IR
raccords pour le soudage bout à bout et électrosoudable - IR
fittings for butt and electro socket welding - IR

PP-R

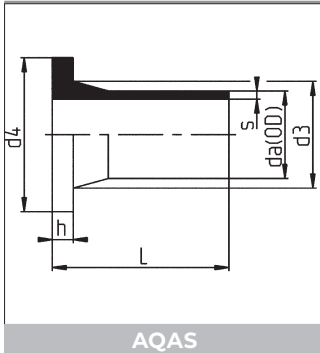

VOORLASKRAGEN. VERLENGD
COLLETS ALLONGEES
STUBS ELONGATED

Gespoten. Ook geschikt voor electromoflas.
Injectées. Convient également pour l'électrosoudage.
Moulded. Also suitable for electro socket welding.

SDR 11 / ISO S-5

da	s	L	L3	d3	d4	h	KG/ST/PC	€/ST/PC
20	1.9	88.0	64	27	45	7	0.020	4.21
25	2.3	88.0	64	33	58	9	0.035	4.39
32	2.9	89.0	61	40	68	10	0.054	5.12
40	3.7	102.0	67	50	78	11	0.083	6.08
50	4.6	102.0	69	61	88	12	0.118	7.39
63	5.8	124.0	78	75	102	14	0.210	9.36
75	6.8	127.5	89	89	122	16	0.295	12.08
90	8.2	143.0	104	105	138	17	0.438	15.78
110	10.0	162.0	115	125	158	18	0.705	20.08
125	11.4	173.0	124	132	158	25	0.841	24.48
140	12.7	193.0	133	155	188	25	1.240	35.22
160	14.6	203.0	148	175	212	25	1.680	47.70
180	16.4	213.0	158	183	212	30	1.940	61.12
200	18.2	213.0	140	232	268	32	3.080	86.71
225	20.5	213.0	145	235	268	32	3.180	89.43
250	22.7	210.0	132	285	320	35	4.500	137.02
280	25.4	220.0	143	288	320	35	5.000	166.91
315	28.6	238.0	154	335	370	35	7.000	221.96



electromoflasfittings
raccords pour electrosoudable
fittings for electro socket welding

PP-R

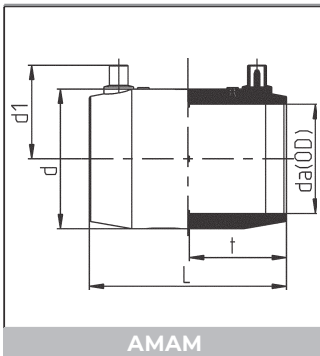

ELECTROLASMOFFEN
MANCHONS ELECTRO-SOUDAGE
ELECTRO WELDING SLEEVES

Geschikt voor PP. 40 V
Pour PP. 40 V
For PP. 40 V

da	L	d	d1	t	SDR	KG/ST/PC	€/ST/PC
20	75	31.2	35.0	38.0	7.4-6	0.040	24.26
25	81	36.2	38.0	41.0	11-6	0.048	27.78
32	87	44.0	42.0	44.0	11-6	0.066	30.93
40	98	55.0	44.5	49.0	11-6	0.104	32.57
50	110	65.0	50.0	55.0	17-6	0.140	45.34
63	126	80.0	56.5	63.0	17-6	0.220	48.11
75	141	97.0	65.5	70.0	17-6	0.350	74.28
90	142	114.0	73.0	70.0	17-6	0.494	97.79
110	153	140.0	83.0	75.0	17-6	0.780	111.59
125	171	161.0	90.5	85.0	17-11	1.260	174.48
140	181	180.0	98.0	90.0	17-11	1.600	197.87
160	181	200.0	108.5	90.0	17-11	1.710	226.69
180	202	222.0	119.0	99.0	17-11	2.360	398.50
200	217	246.0	129.0	106.5	17-11	3.180	374.65
225	233	277.0	144.0	115.0	17-11	4.300	461.97
250	242	310.0	159.0	119.0	17-11	5.680	1031.76
280	254	349.0	180.0	125.0	17-11	7.400	1510.57
315	262	393.0	201.0	130.0	17-11	10.330	1680.97
355	282	445.0	225.0	140.0	17-11	14.750	1961.95



moflafittings
raccords pour le soudage dans l'emboîture
fittings for socket welding

PP

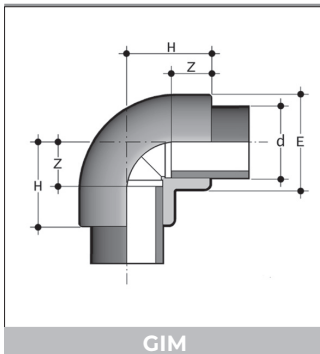

KNIEEN 90°
COUDES A 90°
ELBOWS 90°

PN 10

Gespoten
Injectés
Moulded

D	H	Z	E	€/ST/PC
20	27.5	13.0	27.5	4.01
25	32.0	16.0	33.5	4.81
32	37.0	20.0	41.5	5.80
40	42.5	22.0	51.5	7.30
50	51.0	27.5	63.5	13.49
63	61.0	33.5	78.5	17.53
75	73.0	42.0	92.5	36.43
90	64.5	49.0	110.5	44.73
110	100.5	59.0	135.0	67.09

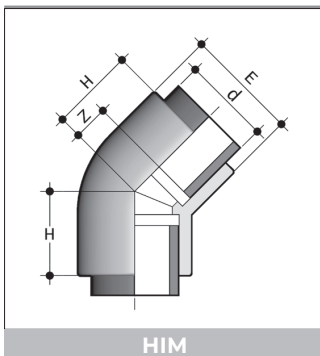

KNIEEN 45°
COUDES A 45°
ELBOWS 45°

PN 10

Gespoten
Injectés
Moulded

d	D	L	Z	€/ST/PC
20	27.5	21.0	6.5	5.80
25	33.5	24.5	8.5	6.18
32	42.0	29.0	12.0	7.58
40	51.5	35.5	15.0	10.52
50	63.0	42.5	19.0	13.49
63	79.0	51.0	23.5	17.94
75	93.0	51.0	20.0	33.25
90	114.0	58.0	23.0	46.61
110	135.0	68.0	27.0	69.13



moflasfittings
raccords pour le soudage dans l'emboîture
fittings for socket welding

PP

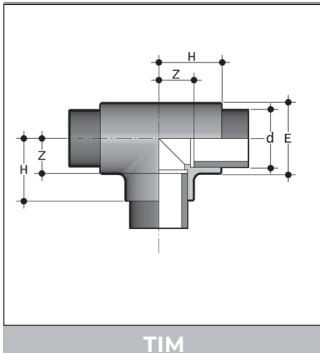

T-STUKKEN 90°
TES A 90°
TEES 90°

PN 10

Gespoten
Injectés
Moulded

D	H	Z	E	€/ST/PC
20	27.5	13.0	27.5	4.60
25	31.5	15.5	33.5	5.27
32	37.0	19.0	41.5	6.18
40	42.0	22.5	52.0	7.93
50	52.0	28.5	64.0	14.05
63	62.5	35.0	79.5	17.88
75	71.0	40.0	92.5	41.52
90	81.5	46.0	110.5	66.98
110	99.5	58.0	134.5	85.05

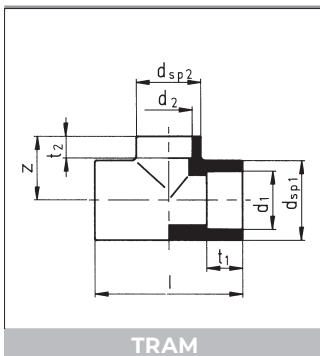

VERLOOP T-STUKKEN 90°
TES REDUITS A 90°
REDUCED TEES 90°

PN 10

Gespoten
Injectés
Moulded

d1 x d2	dsp1	dsp2	t1	t2	l ¹	z	KG/ST/PC	€/ST/PC
25 x 20	34.8	29.9	18.4	16.1	68.5	31.9	0.04	5.46
32 x 20	43.0	29.9	20.0	16.1	79.7	39.8	0.05	6.68
32 x 25	43.0	35.0	20.0	18.0	79.5	40.0	0.06	6.68
40 x 20	53.0	29.7	21.7	16.1	89.9	44.8	0.08	7.60
40 x 25	53.2	35.3	21.7	18.0	90.5	46.8	0.08	7.60
40 x 32	53.0	43.0	21.5	19.0	91.0	45.0	0.10	7.60
50 x 20	65.4	30.0	25.0	16.0	110.0	50.0	0.16	12.26
50 x 25	65.5	35.5	25.0	18.0	110.0	51.0	0.16	12.26
50 x 32	65.0	43.0	24.0	19.0	108.0	54.0	0.17	12.26
50 x 40	65.0	53.0	24.5	21.0	107.0	52.5	0.17	12.26
63 x 25	81.0	36.0	28.6	17.6	130.0	65.0	0.27	17.95
63 x 32	81.0	43.5	28.6	19.1	130.0	65.0	0.27	17.95
63 x 40	81.0	53.0	28.6	21.5	130.0	65.0	0.28	17.95
63 x 50	81.0	66.0	28.6	24.0	130.0	65.0	0.28	17.95



moflasmittings
raccords pour le soudage dans l'emboîture
fittings for socket welding

PP

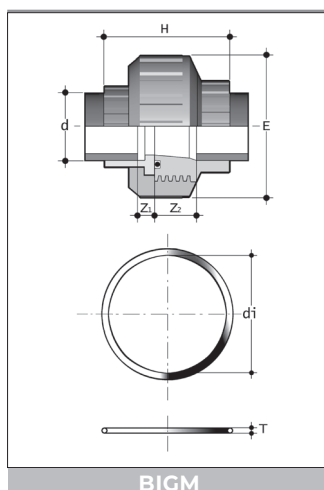

BICGM

DRIEDELIGE KOPPELINGEN
RACCORDS UNION
SOCKET UNIONS

PN 10

Gespoten. Beide zijden inwendige lasmof.
Afdichting: O-ring in EPDM of FPM.

Injectés. Deux côtés femelles à souder.
Etanchéité: joint torique en EPDM ou en FPM.

Moulded. Both ends for socket welding.
Sealing: O-ring made of EPDM or FPM.

D	R1	Z1	Z2	H	E	€/ST/PC	
						EPDM	FPM
20	1"	12	5.5	45.5	47	15.62	18.30
25	1 1/4"	12	5.5	49.5	58	17.49	20.08
32	1 1/2"	12	5.5	53.5	65	20.08	23.81
40	2"	14	5.5	59.5	78	25.32	31.86
50	2 1/4"	16	5.5	67.5	85	36.28	44.65
63	2 3/4"	20	5.5	79.5	103	51.71	61.54

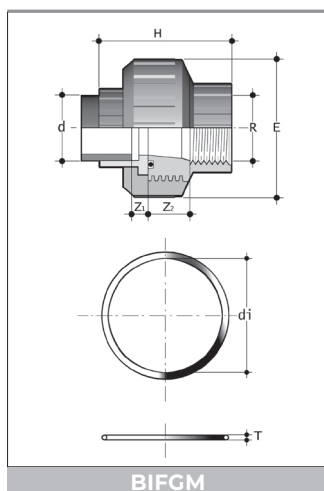

BIFGM

DRIEDELIGE KOPPELINGEN
RACCORDS UNION
SOCKET UNIONS

PN 10

Gespoten. Eén zijde inwendige lasmof, andere zijde cilindrische binnendraad.
Afdichting: O-ring in EPDM of FPM

Injectés. Un côté femelle à souder, un côté femelle à filetage cylindrique.
Etanchéité: joint torique en EPDM ou en FPM .

Moulded. One end for socket welding, other end with interior parallel thread.
Sealing: O-ring made of EPDM or FPM.

D x R	R1	L1	Z1	Z2	H	E	€/ST/PC	
							EPDM	FPM
20 x 1/2"	1"	15.0	5.5	16.0	50.5	47	23.81	27.79
25 x 3/4"	1 1/4"	16.3	5.5	16.7	54.5	58	26.10	29.96
32 x 1"	1 1/2"	19.1	5.5	16.9	59.5	65	27.35	33.35
40 x 1 1/4"	2"	21.4	5.5	19.6	66.5	78	42.65	54.23
50 x 1 1/2"	2 1/4"	21.4	5.5	23.6	73.5	85	62.41	77.49
63 x 2"	2 3/4"	25.7	5.5	24.3	82.5	103	71.72	85.05



moflasfittings
raccords pour le soudage dans l'emboîture
fittings for socket welding

PP

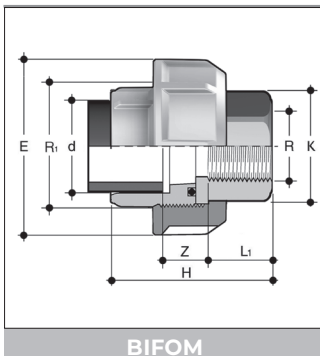

BIFOM

DRIEDELIGE KOPPELINGEN
RACCORDS D'ADAPTATION 3 PIECES
SOCKETS UNIONS

Inlegstuk: PP met lasmof
Puntstuk: messing met parallel binnendraad
Wartelmoer: PP
Afdichting: O-ring EPDM

Pièce folle: PP, côté femelle à souder
Pièce taraudée: laiton, femelle à filetage parallèle
Ecrou: PP
Etanchéité: joint torique EPDM

Insert: PP, socket for socket welding
Close end: brass with parallel female threaded
Union nut: PP
Sealing: O-ring EPDM

d x R	R1	PN	L1	Z	H	K	E	€/ST/PC
20 x 1/2"	1"	10	16.5	18.0	48.5	25	47	27.51
25 x 3/4"	1 1/4"	10	18.5	19.0	53.5	32	58	33.57
32 x 1"	1 1/2"	10	19.5	20.0	57.5	38	65	41.93
40 x 1 1/4"	2"	10	21.5	23.0	64.5	48	78	51.72
50 x 1 1/2"	2 1/4"	10	23.0	32.5	78.5	55	85	66.80
63 x 2"	2 3/4"	10	27.0	31.5	85.5	69	103	86.72

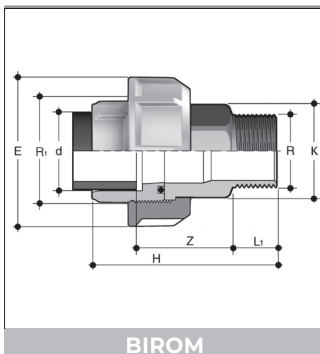

BIROM

DRIEDELIGE KOPPELINGEN
RACCORDS D'ADAPTATION 3 PIECES
SOCKETS UNIONS

Inlegstuk: PP met lasmof
Puntstuk: messing met parallel buitendraad
Wartelmoer: PP
Afdichting: O-ring EPDM

Pièce folle: PP, côté femelle à souder
Pièce taraudée: laiton, mâle à filetage parallèle
Ecrou: PP
Etanchéité: joint torique EPDM

Insert: PP, socket for socket welding
Close end: brass with parallel male threaded
Union nut: PP
Sealing: O-ring EPDM

d x R	R1	PN	L1	Z	H	K	E	€/ST/PC
20 x 1/2"	1"	10	13.5	37.5	65.0	25	47	30.95
25 x 3/4"	1 1/4"	10	15.0	40.5	71.5	32	58	37.43
32 x 1"	1 1/2"	10	17.5	42.5	78.0	38	65	48.10
40 x 1 1/4"	2"	10	19.5	47.5	87.0	48	78	63.43
50 x 1 1/2"	2 1/4"	10	19.5	52.5	95.0	55	85	78.18
63 x 2"	2 3/4"	10	24.0	62.5	113.5	69	103	100.76



moflasmittings
raccords pour le soudage dans l'emboîture
fittings for socket welding

PP

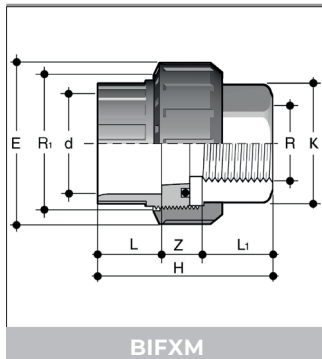

DRIEDELIGE KOPPELINGEN
RACCORDS D'ADAPTATION 3 PIECES
SOCKETS UNIONS

Inlegstuk: PP met lasmof
Puntstuk: RVS A316 L met BSP binnendraad
Wartelmoer: PP
Afdichting: O-ring EPDM of FPM

Pièce folle: PP, côté femelle à souder
Pièce taraudée: inox A316 L, femelle à filetage BSP
Ecrou: PP
Etanchéité: joint torique EPDM / FPM

Insert: PP, socket for socket welding
Close end: BSP threaded A316 L stainless steel female
Union nut: PP
Sealing: O-ring EPDM or FPM

d x R	R1	PN	L1	Z	L	H	K	E	€/ST/PC	
									EPDM	FPM
20 x 1/2"	1"	16	16.5	16.0	16	48.5	25	41	121.69	124.23
25 x 3/4"	1 1/4"	16	18.5	17.0	19	54.5	32	50	147.84	150.48
32 x 1"	1 1/2"	16	19.5	18.0	22	59.5	38	58	172.21	176.00
40 x 1 1/4"	2"	16	21.5	21.0	26	68.5	48	72	208.17	214.78
50 x 1 1/2"	2 1/4"	16	23.0	30.5	31	84.5	55	79	228.30	236.87
63 x 2"	2 3/4"	16	27.0	29.5	38	94.5	69	98	250.85	260.92

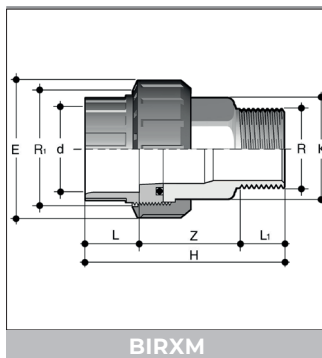

DRIEDELIGE KOPPELINGEN
RACCORDS D'ADAPTATION 3 PIECES
SOCKETS UNIONS

Inlegstuk: PP met lasmof
Puntstuk: RVS A316 L met BSP buitendraad
Wartelmoer: PP
Afdichting: O-ring EPDM of FPM

Pièce folle: PP, côté femelle à souder
Pièce taraudée: inox A316 L, mâle à filetage BSP.
Ecrou: PP
Etanchéité: joint torique EPDM ou FPM

Insert: PP, socket for socket welding
Close end: BSP threaded A316 L stainless steel male
Union nut: PP
Sealing: O-ring EPDM or FPM

d x R	R1	PN	L1	Z	L	H	K	E	€/ST/PC	
									EPDM	FPM
20 x 1/2"	1"	16	13.5	35.5	16	65.0	25	41	136.90	139.50
25 x 3/4"	1 1/4"	16	15.0	38.5	19	72.5	32	50	164.85	167.51
32 x 1"	1 1/2"	16	17.5	40.5	22	80.0	38	58	197.59	202.41
40 x 1 1/4"	2"	16	19.5	45.5	26	91.0	48	72	255.40	262.00
50 x 1 1/2"	2 1/4"	16	19.5	50.5	31	101.0	55	79	267.19	275.79
63 x 2"	2 3/4"	16	24.0	60.5	38	122.5	69	98	291.45	301.55



moflasfittings
raccords pour le soudage dans l'emboîture
fittings for socket welding

PP

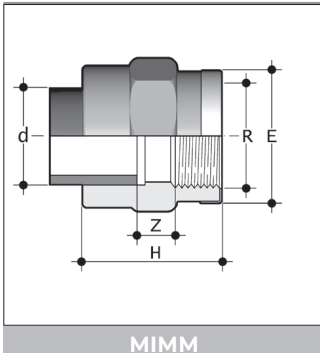

MIMM

OVERGANGSSTUKKEN
EMBOUTS D'ADAPTATION
ADAPTOR COUPLINGS

PN 10

Gespoten.

Eén zijde inwendige lasmof, andere zijde cilindrische binnendraad met RVS versterkingsring.

Injectés.

Un côté femelle à souder, un côté femelle à filetage cylindrique renforcé d'une bague en inox.

Moulded.

One end for socket welding, other end with interior parallel thread with RVS reinforcing ring.

D x R	H	Z	E	€/ST/PC
20 x 1/2"	37.5	8.5	30	5.44
25 x 3/4"	40.0	8.0	39	6.88
32 x 1"	44.0	7.0	47	8.72
40 x 1 1/4"	49.0	8.0	55	10.49
50 x 1 1/2"	53.5	9.0	66	17.26
63 x 2"	62.0	9.0	83	21.77

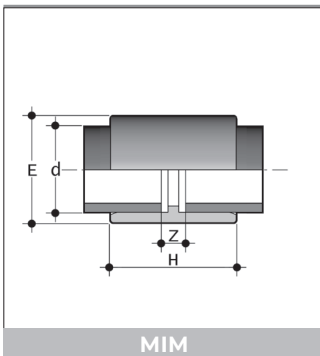

MIM

SOKKEN
MANCHONS
SOCKETS

PN 10

Gespoten.

Injectés.

Moulded.

D	H	Z	E	€/ST/PC
20	36.5	7.5	27.5	2.83
25	40.0	8.0	33.5	3.21
32	44.5	8.5	42.0	3.68
40	48.5	7.5	52.0	4.40
50	55.5	8.2	63.0	8.37
63	64.0	9.0	77.5	12.75
75	72.0	10.0	91.0	17.78
90	81.0	10.0	109.0	25.34
110	93.0	10.0	132.0	39.81



moflasfittings
raccords pour le soudage dans l'emboîture
fittings for socket welding

PP

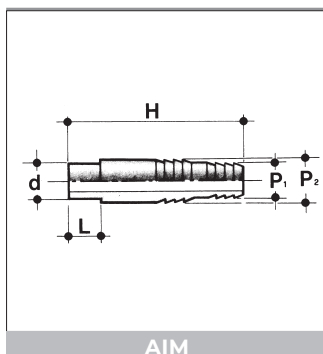

AIM

SLANGPILAREN
EMBOUTS CANNELES
HOSE ADAPTORS

PN 10

Gespoten, met uitwendig laseinde.
Injectés, un côté mâle à souder.
Moulded, with exterior welding end.

D x P1 x P2	L	H	€/ST/PC
20 x 20 x 22	16	67	4.13
25 x 25 x 27	18	81	5.27
32 x 32 x 30	20	95	6.37
40 x 40 x 42	22	104	11.05
50 x 50 x 52	25	111	13.78
63 x 60 x 64	29	122	15.82

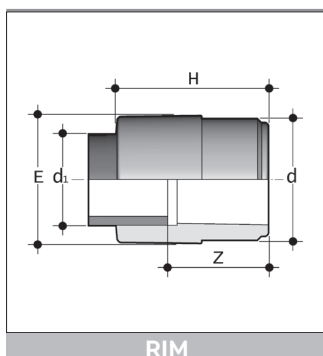

RIM

VERLOOPSTUKKEN
REDUCTIONS
REDUCERS

PN 10

Gespoten, met in- en uitwendig laseinde.
Injectés, côté mâle et femelle à souder.
Moulded, with interior and exterior welding ends.

D x D1	H	Z	E	g	€/ST/PC
25 x 20	39.0	24.5	28.0	10	3.87
32 x 20	43.0	30.0	33.5	13	4.81
32 x 25	46.0	30.0	33.5	17	4.81
40 x 25	48.0	33.0	42.0	24	5.44
40 x 32	51.0	33.0	42.0	27	5.64
50 x 32	54.0	36.0	51.5	39	7.27
50 x 40	56.5	36.0	51.5	44	7.13
63 x 32	61.0	44.0	65.0	69	8.56
63 x 50	67.5	44.0	65.0	76	8.72
75 x 50	69.0	47.0	77.5	106	15.62
75 x 63	74.5	47.0	77.5	115	15.62
90 x 63	82.0	56.0	91.5	156	21.74
90 x 75	87.5	56.0	91.5	175	21.74
110 x 63	93.0	66.0	111.5	290	29.78
110 x 90	101.5	66.0	111.5	305	30.78



moflasfittings
raccords pour le soudage dans l'emboîture
fittings for socket welding

PP

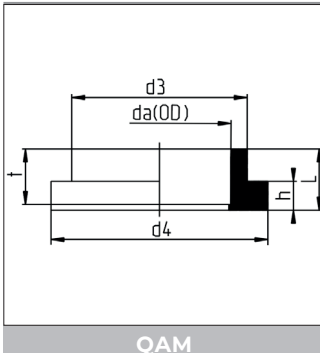

QAM

KRAAGBUSSEN VLAK
COLLETS A JOINT PLAT
FLAT-SEATED STUBS

PN 10

Gespoten
Injectés
Moulded

d	L	d3	d4	h	t	G/ST/PC	€/ST/PC
20	21	27.0	45	10.0	16	0.01	3.82
25	23	33.0	58	10.0	18	0.03	4.05
32	26	40.8	68	10.0	20	0.03	4.49
40	26	50.0	77	10.5	22	0.04	5.56
50	30	61.5	88	13.0	24	0.06	6.64
63	34	76.6	102	14.0	29	0.09	8.58
75	38	91.2	121	16.0	32	0.14	16.67
90	40	105.0	138	17.0	37	0.19	25.73
110	47	131.0	158	18.0	42	0.29	38.20

OVERSCHUIFFLENZEN MET STALEN KERN - PP-GFK
BRIDES LIBRES AVEC NOYAU EN ACIER - PP-GFK
BACKING FLANGES WITH STEEL INSERT - PP-GFK

PN 10

Materiaal: PP, versterkt met 30% glasvezel, met stalen kern. Zie hoofdstuk flenzen.
Matériau: PP, renforcé de 30% de fibres de verre, avec noyau en acier. Voir chapitre brides.
Material: PP +30% glassfibre, moulded with steel insert. See chapter flanges.

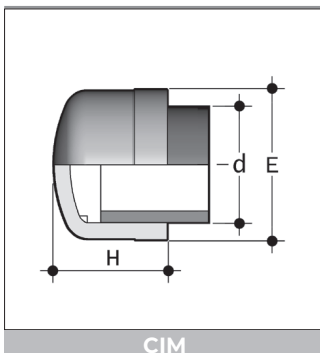

CIM

EINDKAPPEN
BOUCHONS FEMELLES
END CAPS

PN 10

Gespoten.
Injectés.
Moulded.

D	L	E	€/ST/PC
20	24.5	27.5	3.68
25	27.0	33.5	3.68
32	31.5	42.0	4.56
40	35.5	51.0	5.44
50	41.0	63.0	7.66
63	44.0	77.5	9.89
75	48.0	91.0	18.09
90	65.0	109.0	20.92
110	71.0	132.0	28.94

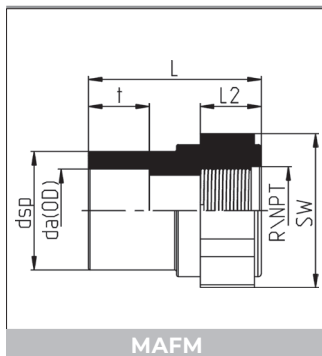
OVERGANGSSTUKKEN
EMBOUTS D'ADAPTATION
ADAPTOR COUPLINGS
PN 10

Gespoten, S-5/SDR 11.
 Eén zijde binnendraad. GFK versterkt.
 Alleen geschikt voor kunststof draadverbindingen.

Injectés, S-5/SDR 11.
 Un côté femelle. Renforcé fibre de verre.
 Uniquement pour des connection matières synthétiques.

Moulded, S-5/SDR 11.
 One end female threaded. Glassfiber reinforced.
 Only for plastic threaded connections.

d	dsp	L	L2	t	K	E	SW	R	KG/ST/PC	€/ST/PC
20	29.0	45.0	16.0	16.0	18.63	20.96	32	1/2"	0.018	7.15
25	35.0	50.5	18.0	18.0	24.12	26.44	41	3/4"	0.032	8.09
32	43.0	57.0	20.0	20.0	30.29	33.25	46	1"	0.045	10.64
40	52.5	62.5	22.0	22.0	38.95	41.91	55	1 1/4"	0.066	12.18
50	65.0	68.0	25.5	24.5	44.85	47.80	70	1 1/2"	0.124	19.10
63	81.0	74.0	30.0	29.5	56.66	59.61	85	2"	0.190	23.93

NPT : op aanvraag / sur demande / on request

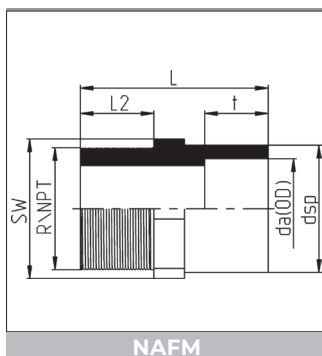
OVERGANGSSTUKKEN
EMBOUTS D'ADAPTATION
ADAPTOR COUPLINGS
PN 10

Gespoten. Draadaansluiting standaard met BS-draad, NPT-draad op aanvraag.
 Injectés. Raccord fileté BS, filetage NPT sur demande.
 Moulded. Standard thread, BS, NPT on request.

d	dsp	L	L2	t	K	E	SW	R	KG/ST/PC	€/ST/PC
20	25	51	20	15.0	24.12	26.44	27	3/4"	0.010	6.72
25	32	61	24	16.5	30.29	33.25	36	1"	0.024	8.52
32	40	66	27	18.6	38.95	41.91	46	1 1/4"	0.040	10.26
40	50	74	29	21.0	44.85	47.80	55	1 1/2"	0.062	16.79
50	63	78	31	24.0	56.66	59.61	65	2"	0.092	21.21

NPT : op aanvraag / sur demande / on request

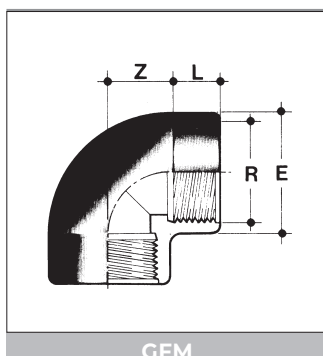

GFM

 KNIIEEN 90°
 COUDES A 90°
 ELBOWS 90°

Beide zijden cilindrische binnendraad.
 Deux côtes femelles à filetage cylindrique.
 Both ends with interior parallel thread.

R	L	Z	E	€/ST/PC
3/8"	15.5	7.5	24.5	3.80
1/2"	16.5	11.0	29.5	5.16
3/4"	19.5	13.0	35.5	7.02
1"	20.0	18.5	43.0	8.52
1 1/4"	20.0	20.0	50.0	13.91
1 1/2"	26.0	26.0	61.0	21.59
2"	32.5	30.5	76.0	26.75

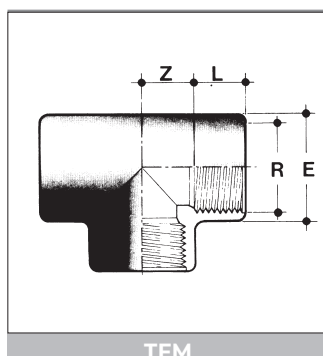

TFM

 T-STUKKEN 90°
 TES A 90°
 TEES 90°

Alle zijden cilindrische binnendraad.
 Trois côtes femelles à filetage cylindrique.
 All ends with interior parallel thread.

R	L	Z	E	€/ST/PC
3/8"	14.5	8.5	24.5	5.07
1/2"	16.5	11.5	29.0	6.10
3/4"	19.5	13.0	35.5	7.52
1"	20.0	19.5	43.0	8.96
1 1/4"	23.0	21.0	57.0	15.84
1 1/2"	26.0	27.0	65.5	24.33
2"	30.5	33.0	80.5	29.43

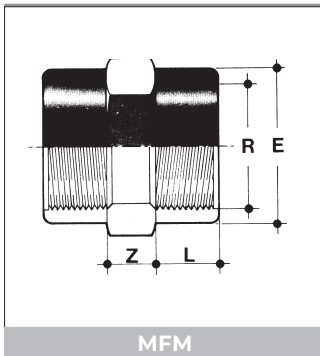

MFM

 SOKKEN
 MANCHONS
 DOUBLE SOCKETS

Beide zijden cilindrische binnendraad.
 Deux côtes femelles à filetage cylindrique.
 Both ends with interior parallel thread.

R	L	Z	E	€/ST/PC
3/8"	15.0	3.0	24.0	4.28
1/2"	16.5	2.5	29.0	5.07
3/4"	19.0	4.0	35.0	5.96
1"	22.0	3.0	43.5	7.56
1 1/4"	23.0	7.0	57.0	10.76
1 1/2"	26.0	6.0	65.0	15.03
2"	29.5	7.0	80.5	21.47

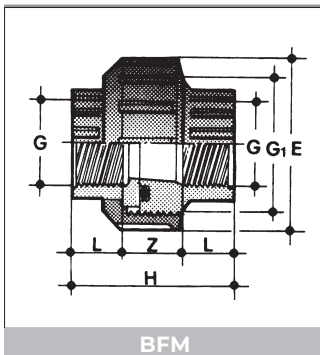

BFM

 DRIEDELIGE KOPPELINGEN
 RACCORDS UNION
 SOCKET UNIONS

Alle zijden cilindrische binnendraad.
 Afdichting: O-ring FPM.

Trois côtes femelles à filetage cylindrique.
 Etanchéité: joint torique FPM.

All ends with interior parallel thread.
 Sealing: O-ring FPM.

R	H	L	Z	E	€/ST/PC
1/2"	51.0	17.0	17.0	53.0	24.97
3/4"	56.0	18.0	20.0	62.0	27.04
1"	62.0	20.5	21.0	70.0	30.54
1 1/4"	68.5	22.5	23.5	81.0	41.43
1 1/2"	76.0	25.0	26.0	88.5	55.94
2"	85.0	29.0	27.0	104.5	76.39

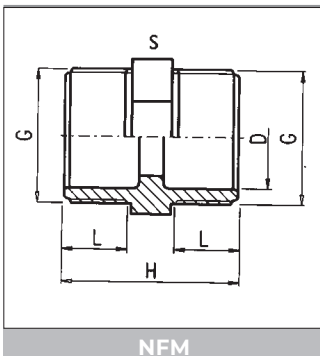

NFM

 DUBBELE NIPPELS
 MAMELONS DOUBLES
 BARREL NIPPLES

Beide zijden cilindrische buitendraad.
 Deux côtes mâle à filetage cylindrique.
 Both ends with exterior parallel threads.

R	L	D	H	S	€/ST/PC
3/8"	15.0	10.0	36.0	20	2.96
1/2"	15.5	13.5	38.0	24	3.33
3/4"	16.0	18.0	38.5	27	4.20
1"	18.5	23.5	43.5	36	5.37
1 1/4"	20.0	30.5	57.5	46	6.34
1 1/2"	20.0	35.0	57.5	54	7.79
2"	24.0	44.5	66.5	63	11.71

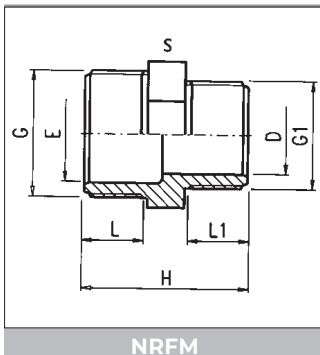

NRFM

 VERMINDERINGSNIPPELS
 MAMELONS DE REDUCTION
 REDUCING BARREL NIPPLES

Beide zijden cilindrische buitendraad.
 Deux côtes mâle à filetage cylindrique.
 Both ends with exterior parallel threads.

G x G1	L	L1	D	E	H	S	€/ST/PC
3/8" x 1/2"	15.5	15.0	10.0	13.5	37.0	24	4.00
1/2" x 3/4"	16.0	15.5	13.5	18.0	38.0	27	5.23
3/4" x 1"	18.0	16.0	17.5	24.0	40.0	36	6.79
1" x 1 1/4"	20.0	18.5	21.5	30.5	55.0	46	7.92
1" x 1 1/2"	20.0	18.5	21.5	35.5	56.0	54	8.96
1 1/4" x 1 1/2"	20.0	20.0	30.5	35.5	57.5	54	9.76
1 1/2" x 2"	24.0	20.5	35.5	44.5	61.5	64	14.41

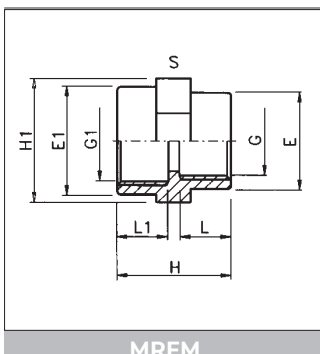

MRFM

 VERMINDERINGSMOFFEN
 MANCHONS DE REDUCTION
 REDUCING SOCKETS

Beide zijden cilindrische binnendraad.
 Deux côtes femelles à filetage cylindrique.
 Both ends with interior parallel threads.

G x G1	E	E1	L	L1	H1	H	S	€/ST/PC
3/4" x 1/2"	28.5	34.5	16	19.0	38.0	38	36	5.77
1" x 3/4"	35.0	42.0	19	23.5	45.5	46	44	7.56

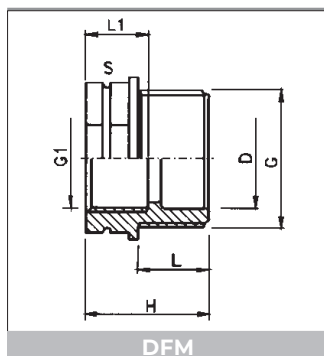

DFM

 VERMINDERINGSBUSSEN
 DOUILLES DE REDUCTION
 REDUCING BUSHES

Met cilindrische binnen- en buitendraad.
 Mâle et femelle à filetage cylindrique.
 Interior and exterior parallel threads.

G x G ₁	H	L	L1	S	€/ST/PC
3/8" x 1/4"	20	10	10	17	5.17
1/2" x 3/8"	26.5	16	15	25	5.17
3/4" x 1/2"	33.0	18.0	17	27	5.94
1" x 3/4"	35.0	19.5	19	36	8.10
1 1/4" x 1"	39.0	21.0	19	46	11.49
1 1/2" x 1 1/4"	39.0	21.0	21	50	16.11
2" x 1 1/2"	43.5	25.5	21	65	22.94

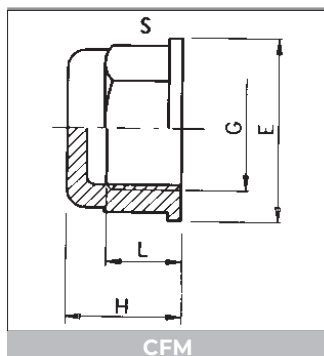

CFM

 AFSLUITKAPPEN
 BOUCHONS
 END CAPS

Met cilindrische binnendraad.
 Femelles à filetage cylindrique.
 Interior parallel threads.

G	E	L	H	S	€/ST/PC
3/8"	26.5	16.0	19.0	23	5.24
1/2"	32.0	16.0	20.5	28	6.22
3/4"	38.0	18.0	24.0	33	6.53
1"	45.0	18.0	25.0	40	7.52
1 1/4"	56.0	20.0	26.5	50	9.37
1 1/2"	63.0	23.0	30.0	57	10.81
2"	75.0	26.5	36.0	71	14.98

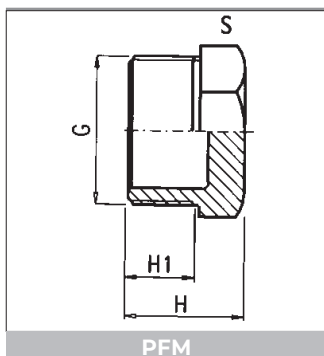

PFM

 DRAADSTOPPEN
 BOUCHONS MALE
 MALE PLUGS

Met cilindrische buitendraad.
 Mâle à filetage cylindrique.
 Exterior parallel threads.

R	H	H1	S	€/ST/PC
3/8"	21.0	13.5	22	2.96
1/2"	22.5	14.0	27	3.33
3/4"	24.0	15.5	34	4.20
1"	25.0	15.5	40	5.37
1 1/4"	39.0	20.0	46	6.34
1 1/2"	39.0	20.0	55	7.79
2"	43.0	24.0	64	11.71

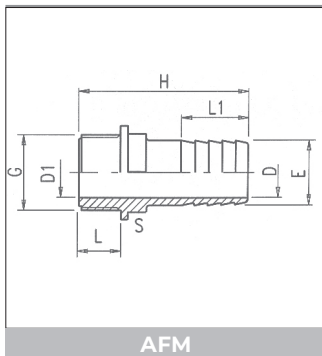

AFM

 SLANGPILAREN
 EMBOUTS CANNELES
 HOSE NOZZLES

G x E	L	L1	D	H	CH	DI	€/ST/PC
1/4" x 12	12.0	27	7.0	48.0	15	7.0	2.35
3/8" x 16	13.5	33	10.0	62.5	20	10.0	2.78
1/2" x 20	13.5	33	15.0	63.0	24	15.0	5.03
3/4" x 25	14.5	36	20.0	68.5	30	19.0	6.47
1" x 30	14.5	33	24.5	72.0	37	24.5	7.61
1 1/4" x 40	15.0	44	34.0	82.0	40	32.0	14.57
1 1/2" x 50	15.5	43	43.0	85.5	50	38.5	17.44
2" x 60	16.0	47	52.0	89.0	60	50.0	18.63

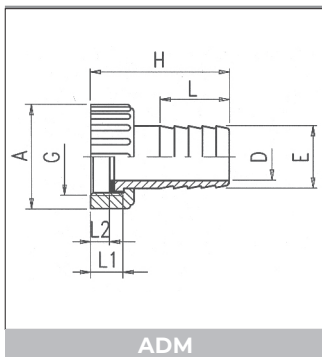

ADM

 SLANGPILAREN
 EMBOUTS CANNELES
 HOSE NOZZLES

Aansluiting met wartelmoer met cilindrische binnendraad.
 Afdichting : vlakke EPDM ring.

Raccordement par écrou femelle à filetage cylindrique.
 Etanchéité : joint plat EPDM.

Connection with parallel threaded nut connection.
 Flat seal : EPDM.

G x E	L1	L2	L	D	H	A	€/ST/PC
3/8" x 12	15.0	9.0	28	7.5	47.0	23.0	8.55
1/2" x 16	16.0	10.0	33	10.0	61.0	27.5	11.22
3/4" x 20	17.0	11.0	33	15.0	62.0	33.0	12.03
1" x 25	18.5	12.0	37	19.5	68.0	40.5	14.57
1 1/4" x 30	18.5	11.5	33	24.5	72.0	51.0	18.63
1 1/2" x 40	19.0	12.0	44	33.5	81.5	57.0	29.37
2" x 50	19.0	12.5	43	43.5	84.5	69.5	37.64



draadfittingen - donkergrijs
raccords filetés - gris foncé
threaded fittings - dark grey

PP

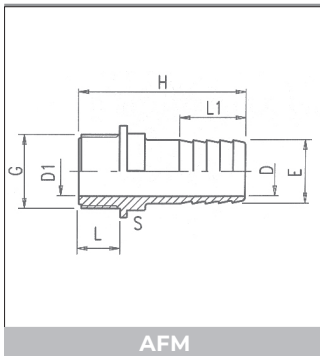

KUNSTSTOF SLANGKOPPELINGEN
EMBOUTS CANNELES EN MATIERE PLASTIQUE
HOSE NOZZLES

PP slangpilaar met buitenschroefdraad. Alleen voor gebruik met water (H₂O)
Opmerking : ook verkrijgbaar in PA uitvoering.

Embout cannelé en PP à filetage extérieur. Uniquement pour l'eau (H₂O)
Remarque : également disponible en PA.

PP hose coupling with exterior thread. Only for use with water (H₂O)
Remark : also available in PA.

G x E	L	L1	D	H	S	DI	€/ST/PC
1/4" x 7	12.0	17.0	4.0	39.5	15	7.0	1.24
1/4" x 9	11.5	22.5	5.5	47.0		7.0	1.24
1/4" x 10	12.0	22.0	7.0	47.0		7.0	1.26
1/4" x 12	12.0	27.0	7.5	48.0	15	7.0	1.26
3/8" x 7	13.5	17.0	4.0	41.0	20	10.0	1.35
3/8" x 10	13.5	22.0	6.0	46.5	20	10.0	1.35
3/8" x 12	13.5	27.0	7.5	52.0	20	10.0	1.35
3/8" x 13	11.0	25.0	7.5	49.5		10.0	1.35
3/8" x 16	13.5	33.0	10.0	63.0	20	10.0	1.56
1/2" x 10	13.0	22.5	6.0	52.5		14.0	1.40
1/2" x 12	14.5	27.0	7.5	58.0		14.0	1.40
1/2" x 13	11.5	25.5	8.0	52.0	22	14.0	1.40
1/2" x 16	13.5	33.0	10.0	62.5	20	14.0	1.58
1/2" x 19	14.5	30.5	14.5	64.5		14.0	1.74
1/2" x 20	13.5	33.0	15.0	63.0	24	15.0	1.74
3/4" x 10	14.5	22.0	6.0	50.0	19	19.0	1.51
3/4" x 12	14.5	27.0	7.5	56.0	19	19.0	1.51
3/4" x 13	14.5	25.0	8.0	57.5	27	18.0	1.51
3/4" x 16	14.5	33.0	11.0	63.5	20	19.0	1.72
3/4" x 20	14.5	33.0	15.0	64.0	24	19.0	1.76
3/4" x 22	16.0	33.5	16.0	68.0		18.0	1.88
3/4" x 25	14.5	36.0	20.0	69.5	30	19.5	1.88
1" x 20	14.5	33.0	14.5	65.0	24	24.0	2.04
1" x 25	14.5	37.0	20.0	69.0	30	24.0	2.06
1" x 30	14.5	35.0	24.5	72.5	37	24.0	2.31
1" x 32	14.5	43.0	26.0	73.0	37	25.0	2.39
1 1/4" x 25	15.0	37.0	20.0	70.0	30	32.0	2.87
1 1/4" x 30	15.0	38.0	25.0	74.0	32	32.0	3.23
1 1/4" x 32	15.0	43.0	26.5	77.5	32	32.0	3.55
1 1/4" x 35	15.5	43.0	29.0	77.5	35	32.5	3.69
1 1/4" x 38	15.5	42.5	32.0	82.0	40	32.5	4.17
1 1/4" x 40	15.5	43.0	34.0	82.0	40	32.5	4.17
1 1/2" x 38	16.0	43.0	32.0	82.0	40	38.5	4.57
1 1/2" x 40	16.0	44.0	34.0	82.0	40	38.0	4.57
1 1/2" x 50	16.0	43.0	43.5	86.0	50	38.5	5.14
2" x 50	16.5	43.0	43.0	86.0	50	48.5	6.38
2" x 60	16.5	47.0	52.0	89.0	60	50.5	9.15



draadfittings - donkergrijs
raccords filetés - gris foncé
threaded fittings - dark grey

PP

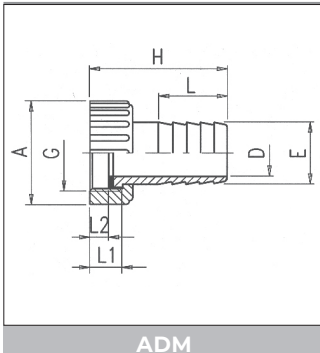

KUNSTSTOF SLANGKOPPELINGEN
EMBOUTS CANNELES EN MATIERES PLASTIQUES
HOSE NOZZLES

PP slangpilaar met binnenschroefdraad en losdraaiende wartel. Dichting EPDM
Alleen voor gebruik met water (H₂O)
Opmerking : ook verkrijgbaar in PA uitvoering.

Embout cannelé en PP à filetage intérieur et écrou libre. Joint en EPDM
Uniquement pour l'eau (H₂O)
Remarque : également disponible en PA.

PP hose coupling with interior thread and free union nut. EPDM gasket
Only for use with water (H₂O)
Remark : also available in PA.

G x E	L ¹	L ²	L	D	H	A	€/ST/PC
1/4" x 7	13.5	8.5	12.0	4.0	38.0	20.0	2.13
3/8" x 9	15.0	9.5	22.0	5.0	47.0	23.0	2.34
3/8" x 10	15.0	10.0	22.0	6.0	45.0	23.0	2.34
3/8" x 12	15.0	9.5	27.0	7.5	47.5	23.0	2.34
1/2" x 10	10		28.0	8.0	50.0	28.0	2.64
1/2" x 13	16.0	9.5	28.5	8.5	52.0	27.5	2.64
1/2" x 16	16.0	9.5	33.0	10.0	61.5	27.5	2.78
3/4" x 10	17.0	11.5	22.0	6.0	47.0	33.0	2.82
3/4" x 12	17.0	11.0	27.0	7.5	53.5	33.0	2.82
3/4" x 13	17.0	11.5	28.0	8.5	53.0	33.0	2.82
3/4" x 16	17.0	11.0	33.0	10.0	62.5	33.0	2.86
3/4" x 19	17.0	11.0	33.0	14.5	62.5	33.0	3.02
3/4" x 20	17.0	10.5	33.0	14.5	63.5	33.0	3.02
1" x 19	11.5		32.5	14.5	57.0	42.5	3.28
1" x 20	18.0	11.5	33.0	14.5	65.0	41.5	3.28
1" x 22	18.0	11.5	37.0	16.5	69.0	41.5	3.28
1" x 25	18.0	12.0	36.0	20.0	69.0	41.5	3.33
1 1/4" x 20	19.0	11.0	33.0	14.5	65.0	51.0	4.08
1 1/4" x 25	19.0	11.5	36.0	20.0	69.0	51.0	4.09
1 1/4" x 30	19.0	11.5	35.0	24.5	72.5	51.0	4.65
1 1/4" x 32	19.0	12.0	43.0	26.0	73.0	51.0	4.65
1 1/2" x 38	12.0		43.0	32.0	81.0	57.0	5.98
1 1/2" x 40	19.0	12.0	43.0	33.5	82.0	57.0	5.89
2" x 50	18.5	11.5	43.0	43.0	84.0	71.0	7.88



draadfittingen - donkergrijs
raccords filetés - gris foncé
threaded fittings - dark grey

PP

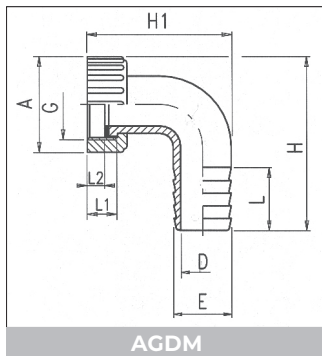

KUNSTSTOF SLANGKOPPELINGEN
EMBOUTS CANNELES EN MATIERES PLASTIQUES
HOSE NOZZLES

Gebogen PP slangpilaar met binnenschroefdraad en losdraaiende wartel. Eveneens leverbaar met driedelige koppeling. Dichting in EPDM. Alleen voor gebruik met water (H₂O)

Opmerking : ook verkrijgbaar in PA uitvoering.

Embout cannelé courbé en PP à filetage intérieur et écrou libre. Aussi livrable avec raccord union. Joint en EPDM. Uniquement pour l'eau (H₂O).

Remarque : également disponible en PA.

Curved PP hose coupling with interior thread and free nut. Also available with socket union coupling. EPDM gasket. Only for use with water (H₂O)

Remark : also available in PA.

G x E	L ¹	L ²	L	D	H	H ¹	A	€/ST/PC
1/2" x 10		10.5	30	7.0	58	49	27.5	3.88
1/2" x 12	16.0	10.5	30	7.0	58	50	27.5	3.88
3/4" x 12	17.0	12.0	30	7.0	61	50	33.0	4.22
3/4" x 16	12.5	7.0	30	11.0	62	48	33.0	4.40
3/4" x 19		8.0	33	11.0	73	56	33.0	4.57
3/4" x 20	12.5	7.0	33	15.0	73	56	33.0	4.57
1" x 22	15.5	10.0	30	17.0	81	60	40.5	5.21
1" x 25	15.5	10.0	30	19.5	82	61	40.5	5.21
1 1/4" x 25	19.0	12.0	30	19.5	87	64	51.0	5.98
1 1/4" x 30	19.0	11.5	28	24.5	94	72	51.0	6.39
1 1/4" x 32	19.0	11.5	32	24.5	94	73	51.0	6.53
1 1/2" x 38		11.5	35	33.0	106	90	57.5	5.73
1 1/2" x 40	19.0	11.5	35	33.0	103	95	57.0	9.56
2" x 50	18.5	12.0	35	42.0	120	97	71.0	12.50



draadfittingen - donkergrijs
raccords filetés - gris foncé
threaded fittings - dark grey

PP

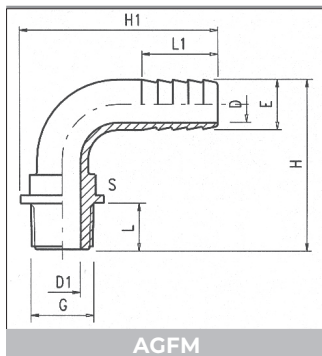

KUNSTSTOF SLANGKOPPELINGEN
EMBOUTS CANNELES EN MATIERES PLASTIQUES
HOSE NOZZLES

Gebogen PP slangpilaar met buitenschroefdraad. Alleen voor gebruik met water (H₂O)
Opmerking : ook verkrijgbaar in PA uitvoering.

Embout cannelé courbé en PP à filetage extérieur. Uniquement pour l'eau (H₂O).
Remarque : également disponible en PA.

Curved PP hose coupling with exterior thread. Only for use with water (H₂O)
Remark : also available in PA.

G x E	L ₁	L	D	H	H ₁	S	D ₁	€/ST/PC
3/8" x 10								2.43
3/8" x 12	12.5	30	7.0	43.0	55	15	10.0	2.43
3/8" x 13								2.43
1/2" x 12	13.5	30	7.0	44.0	57	19	14.0	2.59
1/2" x 13	13.5	30	7.0	44.5	57	19	14.0	2.59
1/2" x 16	13.5	30	11.0	47.0	57	19	14.0	2.78
1/2" x 20	13.5	33	15.0	61.0	70	24	15.5	3.02
1/4" x 10								2.27
1/4" x 12								2.27
3/4" x 12	14.5	30	7.0	45.0	60	19	19.0	2.78
3/4" x 20	14.5	33	15.0	64.0	72	24	19.0	2.98
3/4" x 22	14.5	30	17.0	62.0	78	30	20.0	3.55
3/4" x 25	14.5	30	19.5	64.0	78	30	20.0	3.55
1" x 22	14.5	30	17.0	65.0	80	30	21.0	3.57
1" x 25	14.5	30	19.5	66.0	81	30	19.5	3.57
1" x 30	14.5	28	24.5	68.0	87	37	24.5	4.36
1" x 32	14.5	32	24.5	69.0	87	37	24.5	4.57
1 1/4" x 30	15.5	28	24.5	73.0	91	32	32.5	4.65
1 1/4" x 32	15.5	32	24.5	74.0	91	32	32.5	4.75
1 1/4" x 38								5.21
1 1/2" x 38								5.53
1 1/2" x 40	15.0	35	33.0	85.0	102	40	38.5	5.53