

# **TECHNICAL INFORMATION**

## **DESIGN & INSTALLATION HANDBOOK**

### AGRU Concrete Protective Liner - CPL (*Cast-in-Situ Installation*)







The information provided in this document is believed to be reliable, however no guarantee is made nor can AGRU assume any liability in connection with its use.

Commitments with regard to possible deviations in isolated cases or rights of a third party cannot be implied from this information. All information is subject to change without notice.

This document shall not be reproduced either in full or in part without the written approval of AGRU Kunststofftechnik GmbH Austria.

All information included in this document is based on our current knowledge and experience. In view of the many factors that may affect processing and application, this data does not relieve users from the responsibility of conducting their own tests and experiments; neither does it imply any legally binding assurance of certain properties or of suitability for a specific purpose.

It is the responsibility of those to whom we supply our products to ensure that any applicable proprietary rights and existing laws, standards and legislation are observed.

The statements about all product's relevant properties in our valid catalogues, documents and price lists must to be considered.

# Content

<b>1</b>	<b>INTRODUCTION .....</b>	<b>5</b>
1.1	AGRU ULTRA GRIP®/ SURE GRIP® CPL .....	5
1.2	RANGE OF APPLICATION.....	6
1.3	OUTSTANDING FEATURES.....	6
1.4	SUPPLY RANGE.....	7
1.5	PACKAGING AND TRANSPORTATION .....	7
1.6	TECHNICAL SPECIFICATION FOR AGRU CONCRETE PROTECTIVE LINERS .....	9
1.6.1	<i>Liners</i> .....	9
1.6.2	<i>Profiles</i> .....	9
1.6.3	<i>Design of AGRU Ultra Grip®/ Sure Grip® Concrete Protective Liner</i> .....	10
1.6.4	<i>Ultra Grip® Concrete Protective Liner with anti-skid surface</i> .....	11
1.7	TYPICAL VALUES OF MATERIAL TYPES FOR AGRU CONCRETE PROTECTIVE LINERS .....	12
1.8	PROCESSING OF AGRU CONCRETE PROTECTIVE LINERS .....	13
<b>2</b>	<b>INSTALLATION GUIDELINE FOR AGRU CONCRETE PROTECTIVE LINE GENERAL NOTES .....</b>	<b>16</b>
2.1	ASSEMBLY OF AGRU CONCRETE PROTECTIVE LINERS.....	16
<b>3</b>	<b>WALL – INSTALLATION .....</b>	<b>19</b>
<b>4</b>	<b>ROOF RELINING WITH AGRU CONCRETE PROTECTIVE LINERS .....</b>	<b>23</b>
<b>5</b>	<b>FLOOR LINING WITH AGRU CONCRETE PROTECTIVE LINERS .....</b>	<b>24</b>
5.1	STANDARD METHOD.....	24
5.2	GROUT INJECTION METHOD.....	30
<b>6</b>	<b>FILLING OF VOIDS IN CONCRETE.....</b>	<b>34</b>
<b>7</b>	<b>WALL PENETRATIONS .....</b>	<b>35</b>
<b>8</b>	<b>WELDING OF JOINT GAPS.....</b>	<b>36</b>
<b>9</b>	<b>QUALITY INSPECTION AND DOCUMENTATION .....</b>	<b>36</b>

## 1 Introduction

### 1.1 AGRU Ultra Grip®/ Sure Grip® CPL

The AGRU Ultra Grip®/ Sure Grip® Concrete Protective Liner has been design to seal and protect a wide range of concrete structures. This versatile system consists of thermoplastic liners and accessories such as profiles, semifinished products and welding rod. It is available in a variety of thicknesses and materials.

AGRU Ultra Grip®/ Sure Grip® Concrete Protective Liners are manufactured by means of a special extrusion technique in a continuous process. The unique feature of this process is that liner and studs are formed in one single homogeneous step.

AGRU CPL liners are produced from four basic thermoplastics:

- High Density Polyethylene (HDPE)
- High Density Polyethylene electro conductive (HDPE-el)
- Polypropylene (PP)
- Polyvinylidene Fluoride (PVDF)
- Ethylene-Chlorotrifluoroethylene (ECTFE or Halar)

The AGRU Ultra Grip®/ Sure Grip® Concrete Protective Liner is resistant to acids, caustics and reagents that normally deteriorate concrete. Installation of the system allows the harshest chemicals to be handled, stored and processed without corrosion or penetration of the exposed surfaces.

It protects concrete against chemical attack, abrasion and leakage in precast, relined and cast-in-place structures including, sumps, collection basins, tank farms, trenches, sewers, basements and many other structures.

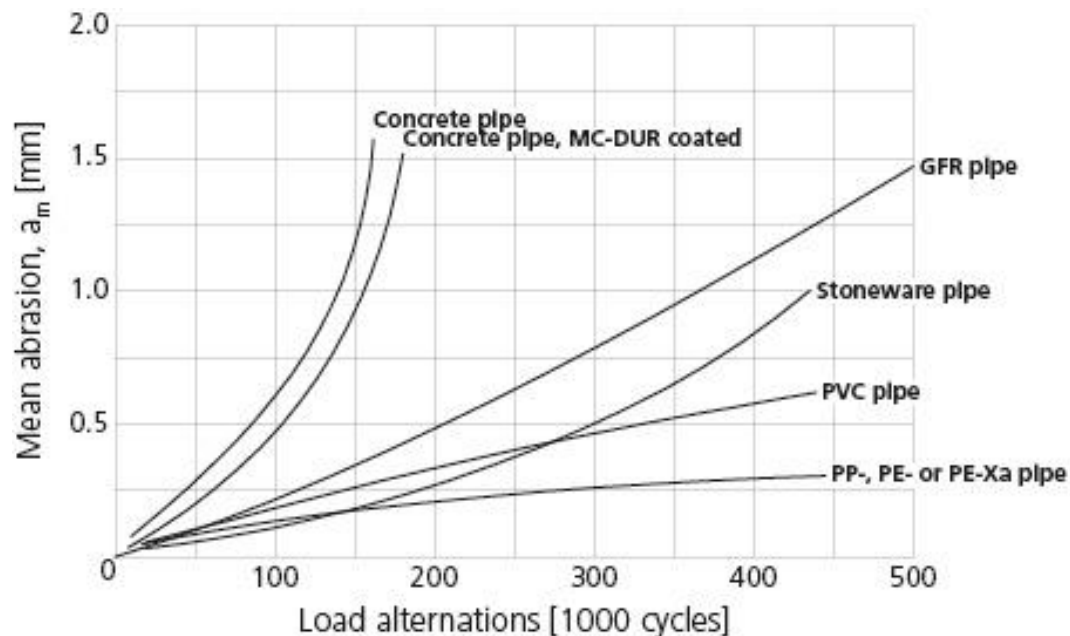

Comparison of abrasion resistance of various materials acc. to Darmstädter Test Method  
Source: Hoechst offprint

In addition, AGRU CPL is available with special features such as the following:

- Anti-skid surface, for safety on lined floors and walking surfaces,
- Self-cleaning surface for minimizing sedimentation in piping systems,
- Fabric facing, which allows a secure connection with other materials; and
- Coextruded liner (two homogeneous layers with differing colors) to enhance damage detection and minimize thermal expansion of the sheets during installation.

For over 30 years AGRU Concrete Protective Liners have been successfully used to protect countless new structures, as well as to rehabilitate existing concrete structures.

## 1.2 Range of Application

- Lining of concrete basins, sewers, reservoirs, industrial effluent trenches and sumps, precast vessels, leachate collection sumps at landfills, sewage systems, water and wastewater treatment plants, digesters and clarifiers
- Lining of concrete pipes, manholes and other structures that are in corrosive service
- Relining of pipelines
- Retrofit or Rehabilitation of unprotected structures, even if already corroded

## 1.3 Outstanding Features

- Anchor studs are an integral part of the sheet, thus providing a strong mechanical bond with concrete. There are no inherent weak points as with concrete liners that have studs individually welded to the sheet or mechanically deformed after production.
- Large number of anchor studs (~420 studs/m<sup>2</sup>; ~39 studs/ft<sup>2</sup>).
- The placement and the design of the studs enable the usage of concrete aggregates up to 20mm.
- Stud design types:
  - Sure Grip® Type 560: 13mm stud height (Standard for PVDF/ ECTFE)
  - Sure Grip® Type 571: 19mm stud height (Only on request)
  - Ultra Grip® Type: 562: 13mm stud height (Standard for HDPE/ PP)
- Available in a variety of thermoplastic materials.
- Easily fabricated, thermoplastics can be formed into virtually any shape.
- Available in a variety of thicknesses, sizes and special designs.
- The only liner of this kind in the World with a maximum width of 5m. This results in reduced field welding and allows bigger precast elements with fewer seams.

## 1.4 Supply range

Product catalogue is available at the AGRU homepage:

<http://www.agru.at/en/products/concrete-protection/product-catalogue/>

or on request.

## 1.5 Packaging and Transportation

Internal quality control (QC) procedures are conducted as an integral part of AGRUS' manufacturing process for Concrete Protective Liners. Once this QC process is cleared the AGRU CPL sheets are placed on stable wooden pallets. Alternatively, CPL rolls are spooled on thermoplastic cores and furnished with a protective PE-wrap. The pallets are stacked in such a way that the loading does not exert any undue pressure on the sides or on the corners of the liners below in order to avoid deformation.

The liners should be protected against direct sun when stored outside to avoid heat absorption and thermal expansion of the liners. This is especially important just prior to installation; otherwise it is not possible to achieve the desired accuracy of fit.

The profiles are delivered in bundles and are protected with a PE-wrap.

Welding rod is supplied on spools or coils, and also protected with a PE-wrap.

For the supplied products, documentation of quality control is available in the form of a certificate 3.1.B acc. to EN 10204 (DIN 50049).



After manufacturing each single roll is wrapped with a protective film which then is marked with all necessary/ specified identification and tracing information prior to transport.



Storage of Sure Grip Concrete Protective Liner Plates



### Abnahmeprüfzeugnis 3.1 nach EN 10204:2005

**Inspection certificate 3.1 acc. to EN 10204:2005 / Certificat 3.1 selon EN 10204:2005**

Gruppennummer: / Group number: / Numéro de groupe: 2018013664 13.02.2019  
 Lieferscheinnummer: / Delivery note: / Numéro de bordereau de livraison: LE18/029574  
 Muster Sample  
 Kunden-Bestell-Nr.: / Customer order number: / N° de commander les clients: 182109482

**Produkt / Product / Produit** 24560402040  
 PE schwarz / PE black / PE noir  
**Betonschutzplatte / Concrete Protective Liner / Plaque de protection béton**  
**Noppen 13mm - 4000X2000mm / studs 13mm - 4000X2000mm / ergot 13mm - 4000X2000mm**  
 extrudiert / extruded / extrusion  
**4000X2000X4,0 DIBt**  
 Extrusionsschweißung / Extrusion-welding / soudage par extrusion

DRAFT

**Seriennummer / Serial Nr. / Numéro de série** 082G2033, 082G3034, 082G1034, 082G2034, 082G3035, 082G1035, 082G2035  
 2017.1  
**Chargennummer / Batch number / Numéro de charge** 18.01.2017 - 20.01.2017  
**Produktionszeitraum / Date of Manufacturing / Période de production**  
**Formmasse / Raw material / Masse de forme** Dowlex 2342M natur/nature + Batch schwarz/black/noir  
**Rohstoffcharge / Batch number / Numéro de charge** F343GC5025  
**Prüfnorm / Test standard / Norme de contrôle** angelehnt an EN ISO 14632  
 according to EN ISO 14632  
 d'après EN ISO 14632

Eigenschaft Characteristic Propriété	Prüfnorm Specification Norme de contrôle	Bedingung Condition Condition	Sollwert Nom. Value Valeur prescrite	Ergebnis Result Résultat	Einheit Unit Unité
MFR - Rohstoff MFR - raw material MFR - test de résin	ISO 1133-1	190°C/5,00kg		2,67	g/10 Min. g/10 min. g/10 min.
MFR - Prüfung Produkt MFR - product MFR - examen de produit	ISO 1133-1	190°C/5,00kg		2,71	g/10 Min. g/10 min. g/10 min.
Lieferzustand appearance Etat de livrer		visuell visual visuel		entspricht fulfilled conforme	
Dimensionskontrolle geometrical characteristics Contrôle de dimension		23°C±2°		entspricht fulfilled conforme	
Oberflächenbeschaffenheit surface character Constitution de surface		visuell visual visuel		entspricht fulfilled conforme	
Thermische Stabilität (OIT) bei 210°C OIT (oxidative induction time) Stabilité thermique de 210 °C	ISO 11357-6	210 °C	≥35	65,75	Min. min. min.
Warmlagerung quer Heat reversion CMD Détermination de la stabilité dimensionnelle ST		120°C/60Min./s3,0		-0,37	% % %
Warmlagerung längs Heat reversion MD Détermination de la stabilité dimensionnelle SP		120°C/60Min./s3,0		-1,32	% % %
Streckdehnung längs Elongation at yield MD Déformation au seuil d'écoulement SP	EN ISO 527		11,05 - 14,95	13,20	% % %
Streckspannung längs Tensile strength of yield MD Résistance au seuil d'écoulement SP	EN ISO 527		14,45 - 19,55	16,11	N/mm² N/mm² N/mm²
Streckdehnung quer Elongation at yield CMD Déformation au seuil d'écoulement ST	EN ISO 527		11,05 - 14,95	13,80	% % %
Streckspannung quer Tensile strength of yield CMD Résistance au seuil d'écoulement ST	EN ISO 527		14,45 - 19,55	15,44	N/mm² N/mm² N/mm²
Dichte Produkt Density product Masse volumique produit fini	ISO 1183		≥0,944	0,941	g/cm³ g/cm³ g/cm³

Die in diesem Werkzeugeingabe angegebenen Prüfergebnisse sind den Aufzeichnungen über die betrieblichen Prüfungen an Halbzeugen aus dem gleichen Werkstoff und der gleichen Herstellungsart wie die Lieferung selbst entnommen.  
 The last results of this certificate have been taken from the records of the internal testings for semi finished products out of the same raw material and the same kind of production as delivery.  
 Les résultats de contrôle indiqués dans ce certificat d'œuvre sont empruntés eux-mêmes aux enregistrements sur les Pröfungen de l'entreprise aux demis témoins du même matériau et la même espèce de production que la livraison.

Dieses Zeugnis wurde mittels EDV erstellt und somit auch ohne original Unterschrift göltig.  
 This certificate was prepared by EDF and therefore is valid also without original signature.  
 Ce certificat fut fait par informatique et il est par conséquent aussi valable sans signature.

DRAFT

Seite/Page 1 von/of/de 1

Test certificate (DE/EN & FR), issued by the quality control department.



## 1.6 Technical Specification for AGRU Concrete Protective Liners

### 1.6.1 Liners

The large number of anchor studs (~420 studs/m<sup>2</sup>; ~39 studs/ft<sup>2</sup>) guarantees the best possible interface and bonding between concrete and Ultra Grip®/ Sure Grip® liner. Moreover, the studs are manufactured during the extrusion process in a one-step process with the sheet, thus creating a homogeneous element. No welding and/ or mechanical finishing work is required to attach the studs to the sheet. The AGRU Concrete Protective Liner and profiles, as well as the necessary welding material (welding rod) must be manufactured out of identical raw material types and supplied by the manufacturer of the CPL.

### 1.6.2 Profiles

All profiles strips are extruded or milled and available in 5m (16.4ft) lengths. End profiles are available in two sizes, for 2mm-3mm and for 3,5mm-5mm sheets. Tear off profile can be used for liners ranging between 2 and 5 mm due to the inherent flexibility of the profile's "wings". Profiles of special length or profiles for CPL with higher wall thicknesses may be available on request.

During the extrusion process, an electro conductive layer is co-extruded in the grooves of the end profiles where the CPL will be welded. This replaces the conductive tape (or copper wire) normally utilized/ required for spark testing. Tear off profiles are made entirely out of electro conductive material.

- The TEAR OFF PROFILE has the same function as an H- connection profile – to connect two sheets on a flat surface. The profile is installed with the flat side facing the concrete formworks. After the concrete has cured, the flat portion of the profile is removed and only a single extrusion weld is required. In addition, tear off profiles assists with placement and alignment of the CPL on the concrete forms and generally provides for a better overall installation. The AGRU tear off profiles made out of HDPE-el material are suitable for all thermoplastic AGRU CPL (e.g. HDPE, PP, PVDF and ECTFE).
- The END PROFILE is used to seal the concrete lining at its edges; most end profiles are used to seal the upper edge of the lining system. (e.g. tank lining)
- CORNERS are injection molded 3-sided, 90° corners. These profiles facilitate welding in confined corner spaces. Corners can be inserted and tack welded to the liners after the concrete has set. Then, the extrusion weld can be made around its three sides thus avoiding an intersection of three welds.

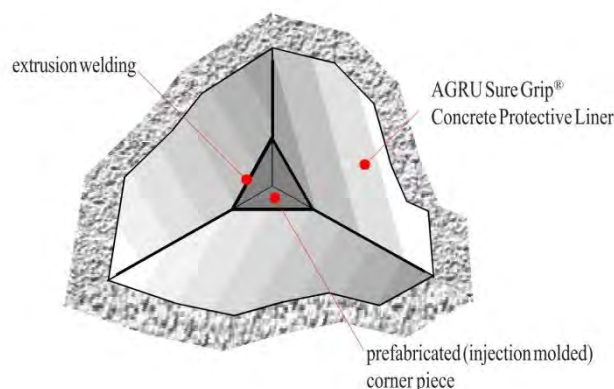

- **I-PROFILE** is used to divide the floor area into sections to accommodate the specific size of CPL sheets used. This profile and the associated procedure is essential for the installation of the concrete protective liner in floor areas.

### 1.6.3 Design of AGRU Ultra Grip®/ Sure Grip® Concrete Protective Liner

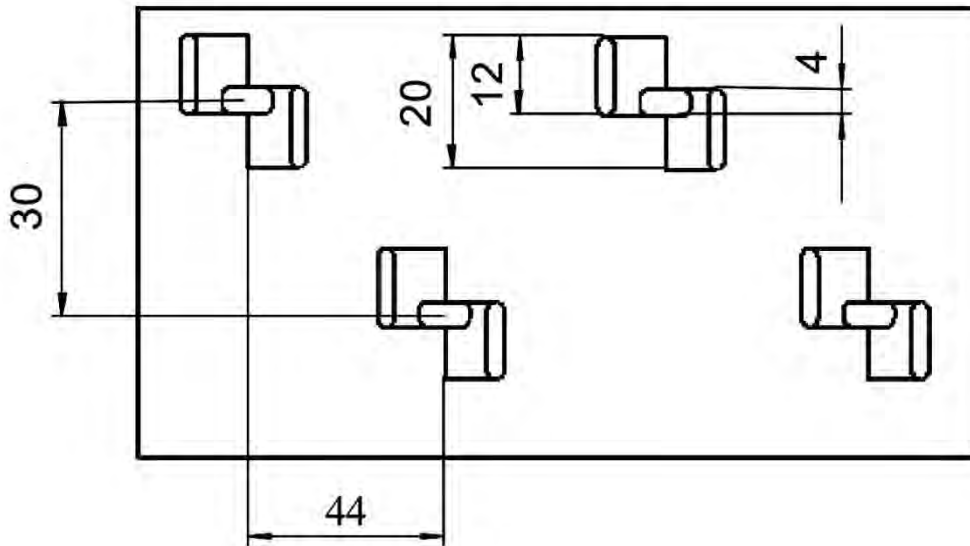

Arrangement of anchor studs (Guide values in mm)

- Type 560 Sure Grip® (13mm stud height)

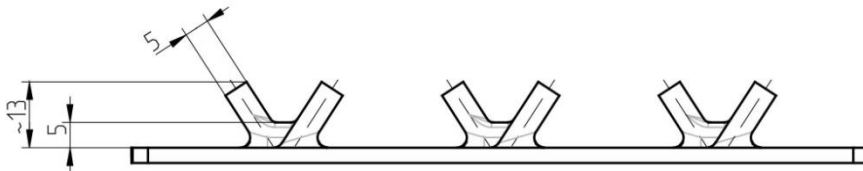

- Type 571 Sure Grip® (19mm stud height)

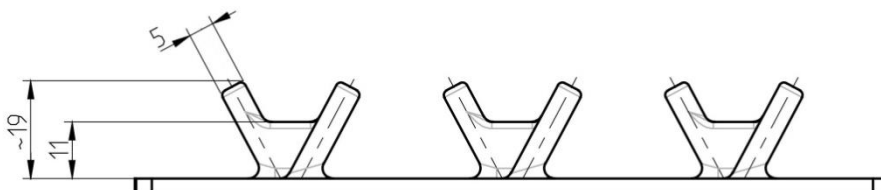

- Type 562 Ultra Grip® (13mm stud height)

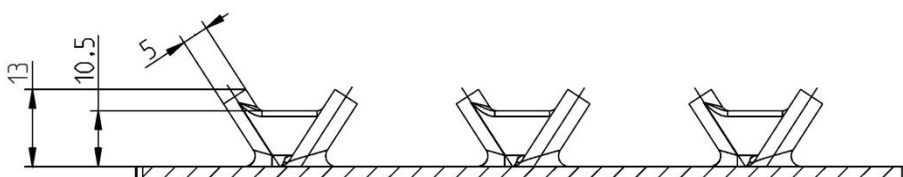

(Guide values in mm)

### 1.6.4 Ultra Grip® Concrete Protective Liner with anti-skid surface

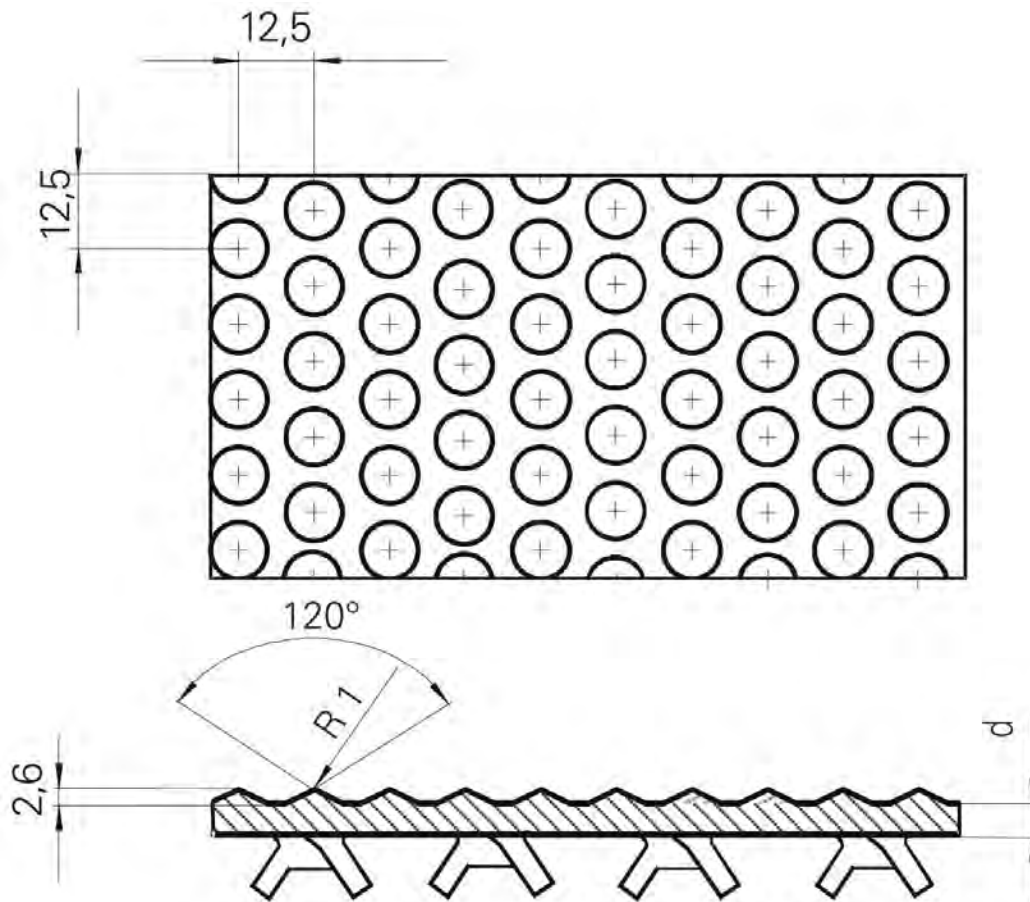

(Guide values in mm)  
Available in HDPE and PP on request.

## 1.7 Typical Values of Material Types for AGRU Concrete Protective Liners

Property	Testing Method	Unit	Typical Values (Guide Values)			
			HDPE*	PP**	PVDF	ECTFE
Density	ISO 1183	g/cm <sup>3</sup>	0.94	0.905	1.78	1.68
Melt Flow Rate	ISO 1133	g/10min	0.4 – 3.0 190/5	0.25 230/2.16	6 230/5	1 190/5
Heat Reversion (Dimensional Stability)	ISO 14632 ISO 15013 ISO 15014	%	<3 at 110°C/ 1,5h	<3 at 135°C/ 1,5h	<3 at 150°C/ 1h	<3 at 160°C/ 1h
Tensile Stress at Yield	ISO 527-3 specimen 1B	N/mm <sup>2</sup>	≥15	≥20	≥25	≥25
Elongation at Yield	ISO 527-3 specimen 1B	%	≥8	≥12	≥8	≥4
Elongation at Break	ISO 527-3 specimen 1B	%	>400	>200	>20	>20
E-Modulus (tensile test; short term)	ISO 527	N/mm <sup>2</sup>	600	900	1050	1675
Fire Classification	DIN 4102/part1 UL 94 EN 13501	- - -	B2 94-HB Class E	B2 94-HB -	- V-0 -	- V-0 -
Specific surface resistance	VDE 0303 ASTM D257	Ohm	>10 <sup>13</sup>	>10 <sup>13</sup>	>10 <sup>14</sup>	-

\*... standard black (guide values for other colors and materials on request)

\*\*... grey (guide values for other colors and materials on request)

The data values in this table are approximate values (guide values) and based upon results of internal inspection, data of raw material suppliers as well as tests in the course of approval procedures and external inspections. The results can differ from the indicated mean values in longitudinal and transverse direction and due to different nominal thicknesses and raw materials. In any case, requirements relating to a special project (tender documents) would have to be agreed to by AGRU.

Independent of the indicated test standards, internal tests and data on test certificates are generally carried out in accordance with the appropriate test procedures according to ÖNORM (Austrian Standard) resp. DIN (German Standard).



AGRU assumes no liability in connection with the use of this data. The specifications on this sheet are subject to change without notice.

Effective as of May 2019

## 1.8 Processing of AGRU Concrete Protective Liners

- Mechanical Processing

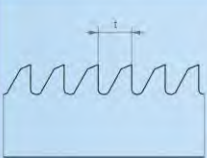
Mechanical machining and cutting of thermoplastics can be easily accomplished with machines and cutting blades that are designed for woodworking.

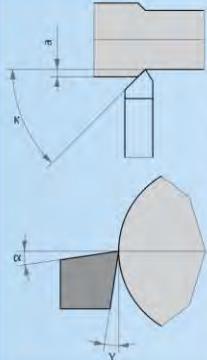
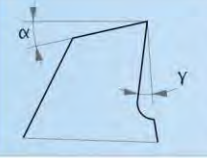
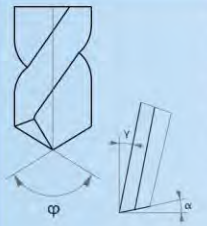
<b>Cutting</b>				
	Clearance angle $\alpha$	[°]	30 - 40*	Band saws are appropriate for the cutting of pipes, blocks, thick sheets and for round parts.
	Rake angle $\gamma$	[°]	10 - 15**	
	Pitch t	[mm]	0 - 8	
	Cutting speed v	[m/min]	2 - 8 up to 3000	
<b>Cutting</b>				
	Clearance angle $\alpha$	[°]	30 - 40*	Circular saws can be used for the cutting of pipes, blocks and sheets. HM saws have a considerably longer working life.
	Rake angle $\gamma$	[°]	10 - 15** 5 - 8*	
	Pitch t	[mm]	0 - 5**	
	Cutting speed v	[m/min]	2 - 8 -	
<b>Turning</b>				
	Clearance angle $\alpha$	[°]	5 - 15	The peak radius (r) should be at least 0,5 mm. High surface quality is obtained by means of a cutting tool with a wide finishing blade. Cut-off: Sharpen turning tool like a knife.
	Rake angle $\gamma$	[°]	0 - 10	
	Tool angle $\kappa$	[°]	45 - 60	
	Cutting speed v	[m/min]	200 - 500	
	Feed s	[mm/U]	0,1 - 0,5	
	Cutting depth a	[mm]	up to 6	
	Peak radius r	[mm]	min. 0,5	
<b>Milling</b>				
	Clearance angle $\alpha$	[°]	5 - 15	High surface quality is obtained by means of a milling machine with fewer blades - this increases cutting capacity..
	Rake angle $\gamma$	[°]	up to 15	
	Cutting speed u	[m/min]	up to 1000	
	Feed s	[mm/U]	up to 0,5	
	Cutting depth a	[mm]	-	
<b>Drilling</b>				
	Clearance angle $\alpha$	[°]	10 - 12	Spiral angles 12 - 16°. For holes with diameters of 40 - 150mm, hollow drills should be used; for holes < 40 mm diameter, use a normal SS-twist drill.
	Rake angle $\gamma$	[°]	3 - 5	
	Centre angle $\varphi$	[°]	60 - 90	
	Cutting speed v	[m/min]	50 - 100	
	Feed s	[mm/U]	0,2 - 0,5	
	Spiral angle $\beta$	[°]	12 - 16	

\*... *high speed steel values*

\*\*... *hard metal values*

- Prefabrication

Prefabrication of AGRU Concrete Protective Liners and profiles should be carried out by using heat element butt welding, hot wedge welding, hot gas string bead welding and hot gas extrusion welding in accordance to the DVS standard.

The removal of studs is often necessary, and appropriate machinery is required to efficiently accomplish this task

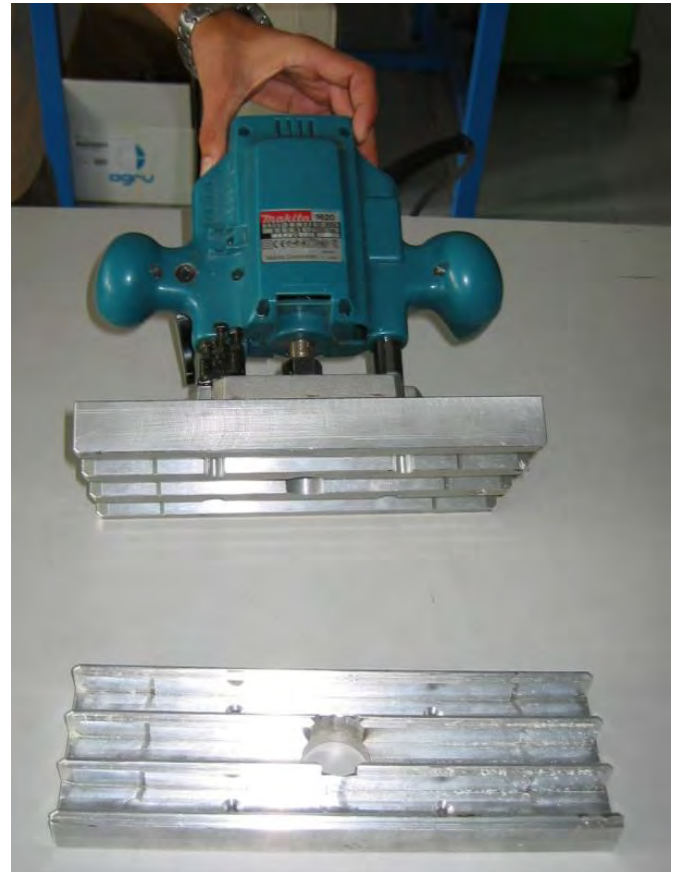
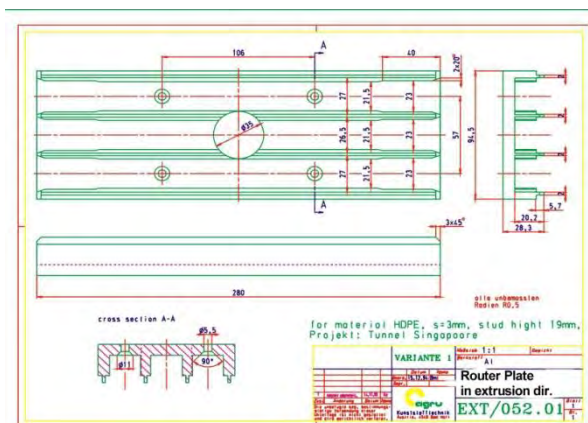
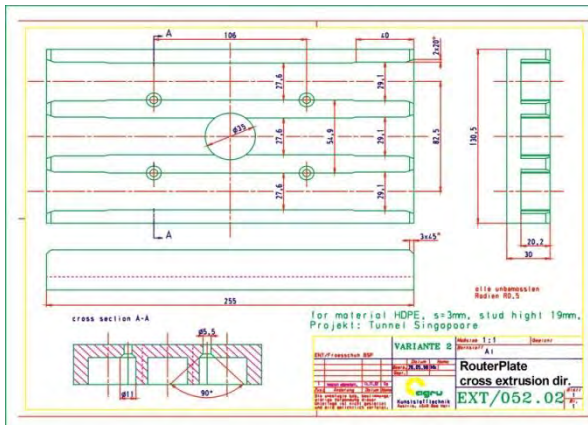

*Guide blocks and special blade used in conjunction with a router to remove stud without damaging the liner (available on request).*

- Thermoforming

Thermoplastics can be formed by heating the desired area to the crystallization point. This critical temperature has to be kept constant as higher temperatures could damage the molecular structure of the material.

Crystallization temperatures acc. DIN 53736 (ASTM D3418):

- HDPE            122-126°C            (252-259°F)
- PP                150-154°C            (302-310°F)
- PVDF            160°C                (320°F)
- ECTFE          240°C                (464°F)



**AGRU recommends prefabrication of corners in a lining system by thermoforming the liners whenever possible. Thermoforming can be performed by special thermoforming devices or manually by hot gas welding machine. Further information is available on request.**

## 2 Installation Guideline for AGRU Concrete Protective Line General Notes

When the CPL sheets are fitted to the wooden formworks, the installer must ensure that no damage is done to the CPL or any prefabricated welding seams. In the event that damage has occurred, the location must be clearly marked, to identify and facilitate therepairs.

Should groundwater be present where the concrete forms are erected, appropriate measures must to be taken in accordance with DIN 18195.

Assembly of the liners on site has to be carried out in accordance with an installation plan by or under the supervision of trained personnel or plastic fabricator who will also carry out the subsequent field welding.

The installation plan should specify the type and location of all welds. Each weld should be assigned with a unique identification label.

This will enable the installer to document his work by means of welding protocols in connection with the installation plan.

### 2.1 Assembly of AGRU Concrete Protective Liners

For the assembly of the liner at the wall sections, a wooden formwork system with a sufficient amount of bracing should be used. This will minimize the number of penetrations of the liner, which will otherwise have to be patched later. e.g. DOKA System → <https://www.doka.com/at/solutions/overview/index?changeCountry=AT>

After the wooden forms have been erected as usual, the liner should be mounted to the forms by using tear off profiles. The liners are fixed to the wooden forms by means of wire nails (used for roofing applications with heads having a minimum diameter of 5-6mm) in the areas where extrusion welding seams (butt joints) will be carried out later. This will ensure that the penetrations caused by the nails are covered and sealed and that the forms can easily be removed.



Whenever the tear off profile is applied, it is recommended to nail through the profiles without penetrating the liner sheets (see page 19). Afterwards, the liner sheets are pulled together by means of wire loops at every 6<sup>th</sup> row of studs and are sufficiently held together inside the formwork. In the event that the studs are offset requiring the wire ties to be placed at an angle care should be taken to alternate the diagonal orientation of the ties to minimize the potential for movement of the liner sheets.

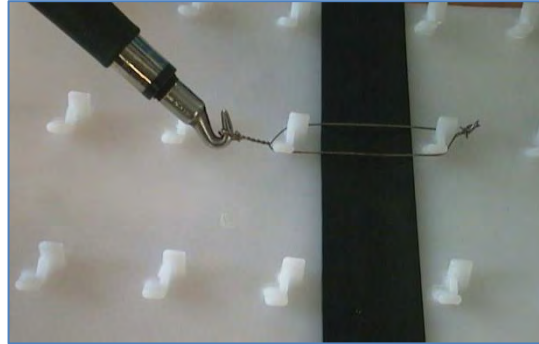

(Example: Connection of CPL by means of wire loops at every 6<sup>th</sup> row of studs)



Important

**The distance between two rows of studs at the joints shall not exceed 1,5 x standard stud row distance. Otherwise the mechanical anchorage at the joint gaps is not properly.**



(Example: Allowable distance between two rows of studs at the joint)

Thermal expansion should be taken into consideration by only nailing the liners at the bottom edges and partially along the side edges. The liners are hung from the top edge of the cast forms by using wire loops, rope loops or hooks and/ or clamping devices. This will allow any wrinkles or waves in the liner to flatten out when the concrete is poured.



Important

**Important note, to avoid wave formation after casting:**

The CPL has to be fixed onto the wooden formwork during the warmer time of the day (e.g. noontime). The casting sequence has to be performed during the cooler time of the day (e.g. morning or evening).

To remove the wooden forms from the liner and cured concrete appropriate crowbars or pry bars must be used. The boards must be removed very carefully so that the liner is not damaged. Once the forms have been removed, all drill holes and nail holes are sealed with patches or by welding directly over the holes

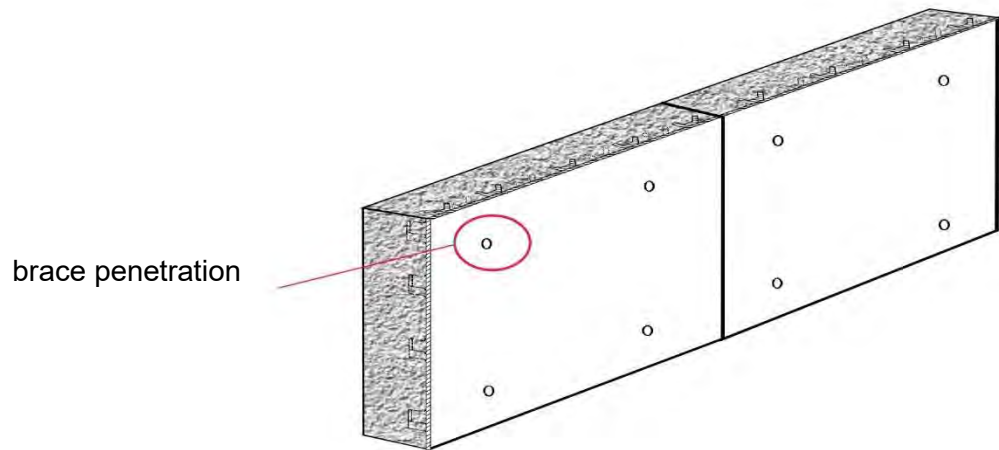

**Option 1:**

Covering hood  
 [execution by means  
 of heated tool groove  
 welding]

**Option 2:**

Cover patch

**Option 3:**

Cover patch

**Option 4:**

Extrusion welding  
 with special round  
 shoe

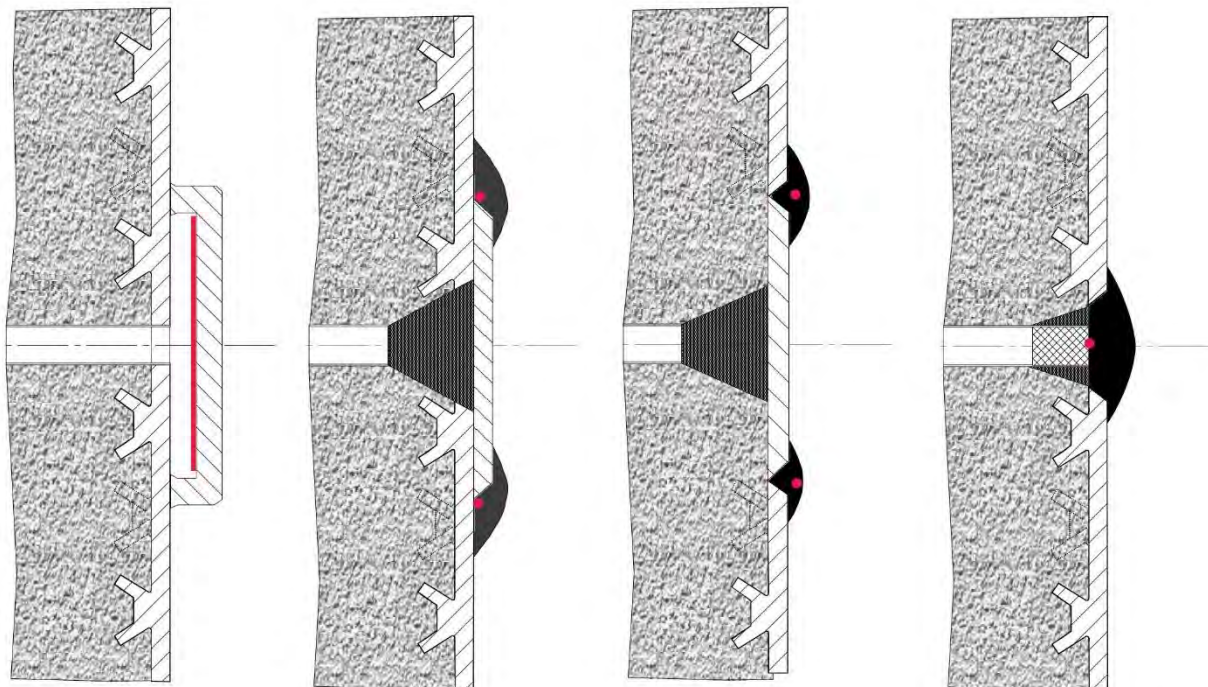

(Measurements acc. to DVS 2227-1).

Timing of formwork removal is dependent upon the quality of the concrete, specifically the curing time. We recommend a minimum concrete compressive strength of 10 N/mm<sup>2</sup> [1450 psi] before formwork is removed.

### 3 Wall – Installation

- 2.5mm – 5.0mm (with tear off profiles)
- 6.0mm – 12.0mm (with support profiles made out of semi-finished sheet)
  
- Tear off profile for joining liners  $\leq 5\text{mm}$  thick

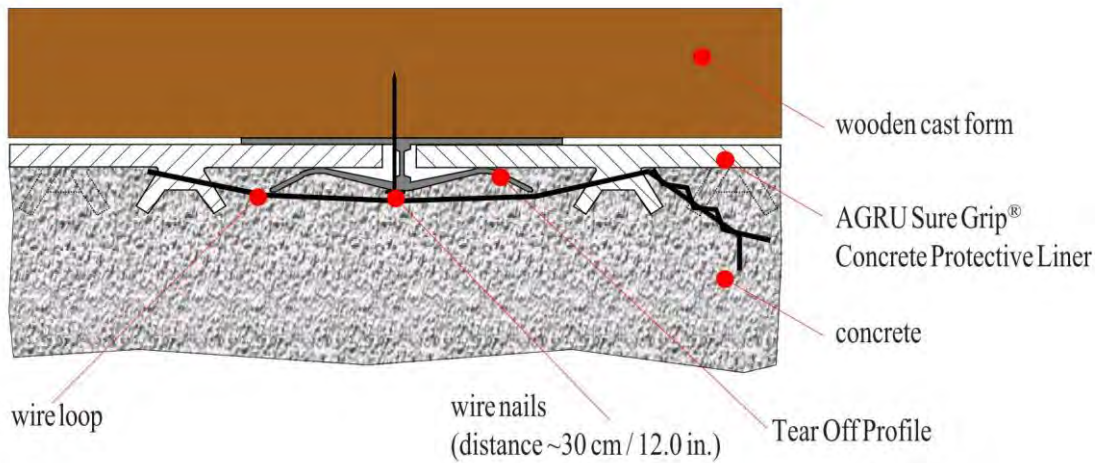

*(Examples: Assembly of AGRU CPL onto wooden formwork – cast in situ applications)*

- Tear off profile joint – prior to welding

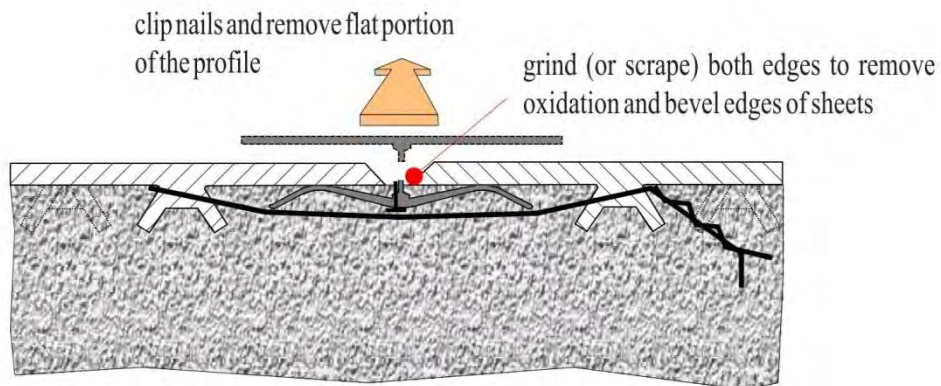

- Tear off profile joint – execution of extrusion welding seam

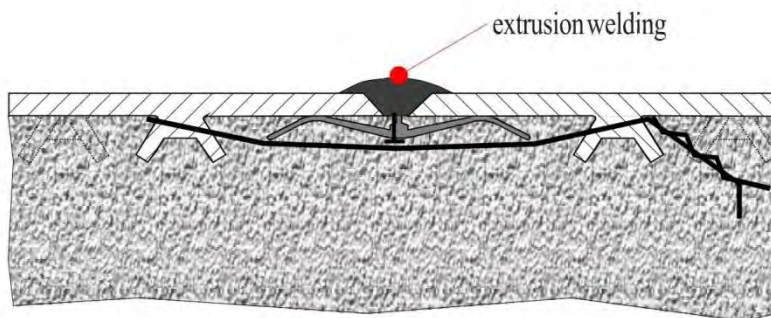

- Thermoformed corners – Outside

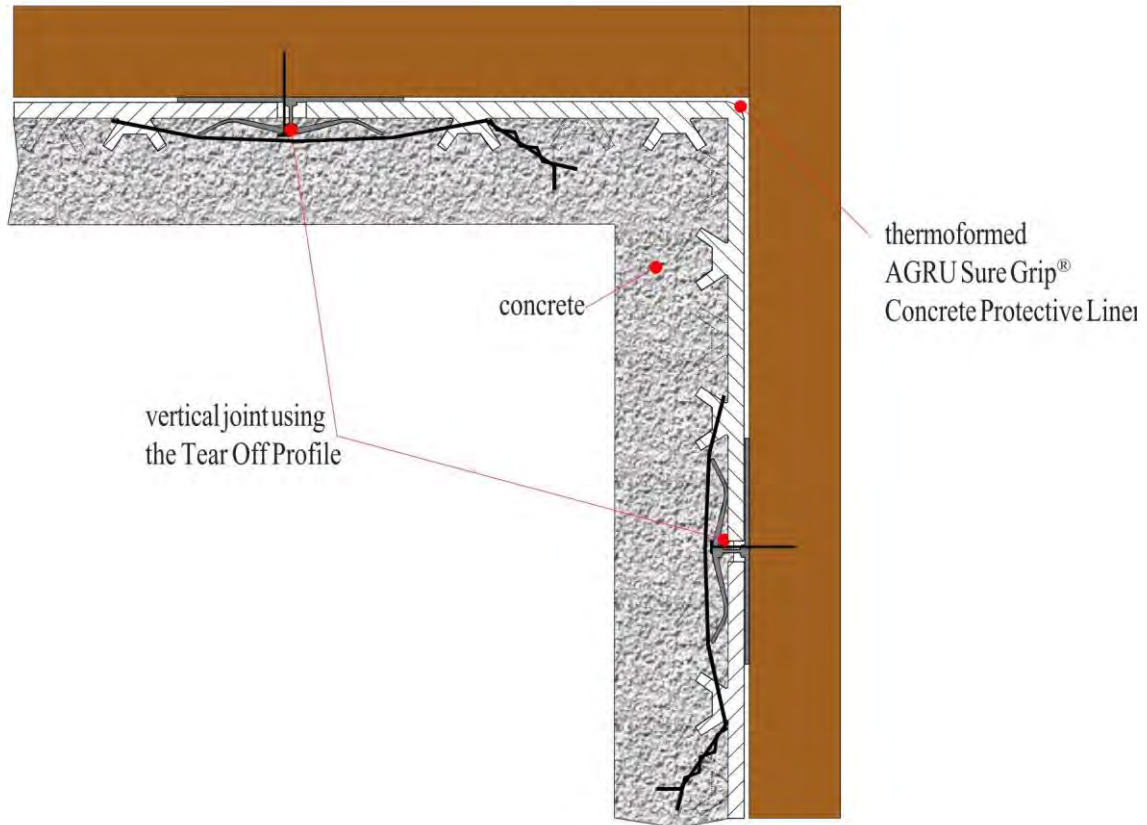

- Thermoformed corners – Inside

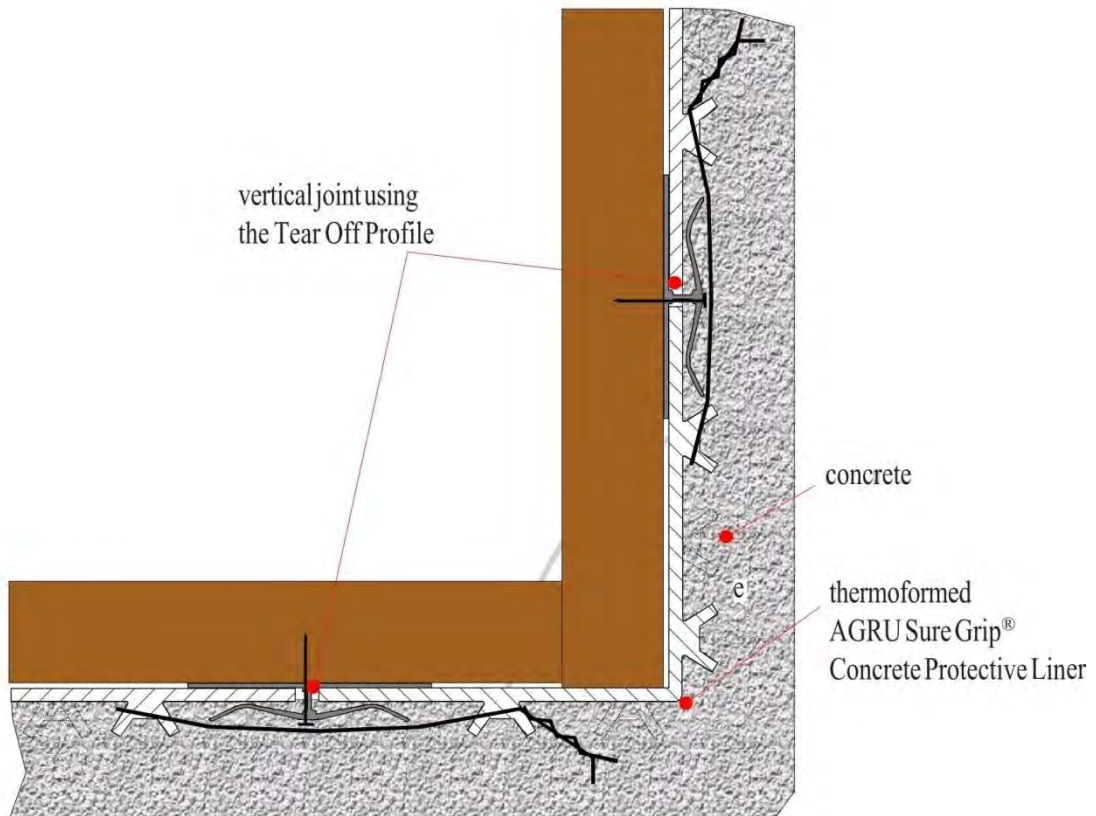

- Termination of the lining system with the end profile for joining liners  $\leq 5\text{mm}$  thick

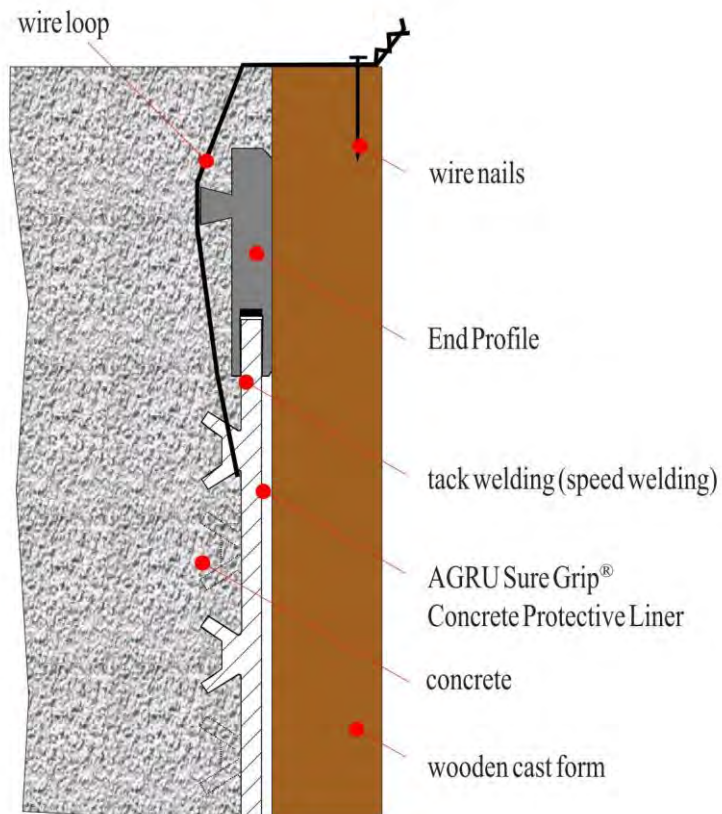

- End profile – execution of extrusion welding seam

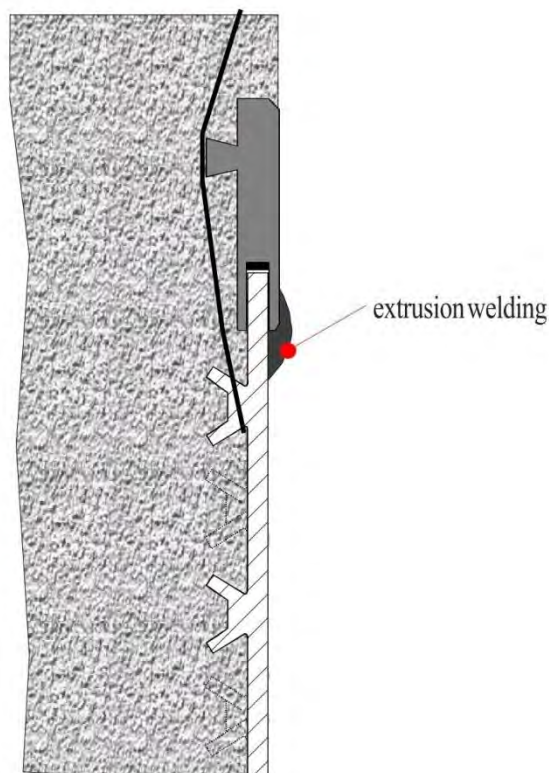

#### 4 Roof Relining with AGRU Concrete Protective Liners

There is no published standard relining procedure for roof/ ceilings. The proposed relining procedure should be discussed with the AGRU's technical department for each project specific installation.



For this discussion it is essential to forward AGRU all appropriate details, photographs and drawings of the existing concrete roof structure and any other relevant details regarding the project.

## 5 Floor lining with AGRU Concrete Protective Liners

- 3.0 – 12.0mm

### 5.1 Standard Method

After the bottom concrete surface (foundation) has been prepared by cleaning with sand blasting or high pressure steam cleaners to remove any residual sludge or other remaining particles, an adhesive coating must be applied in order to ensure adequate bonding between the existing foundation and the floor plaster to be applied. This must be performed according to the recommendation to the responsible engineer and concrete supplier. The bottom surface is then divided into fields that match the size of the concrete protective liners. The arrangement and placement of these fields is accomplished by attaching concrete profiles with an embedded CPL strip, perforated steel profile or the AGRU I-Profile, thus supporting the AGRU CPL.

Perforated profiles ensure a homogenous bonding of the floor plaster between the individual fields. Another method of creating these fields is to build supports out of lean concrete.

Additionally a support must be installed along the entire perimeter of the floor section. It must be ensured that the AGRU CPL is supported at the edges on a bearing surface of at least 20mm (0.8inch) wide on the steel profiles, AGRU I-profiles or the lean concrete supports. Subsequently, the floor plaster is poured in the controlled fields and finished at a slightly raised level (2-3mm/ 0.08-0.12 inch).



**Then the AGRU CPL sheets are rolled into the concrete in each field, entirely covered with wooden boards (plywood), evenly weighted (weight/m<sup>2</sup>: 30-40kg/66-88lbs) and tamped (or vibrated).**

Once the concrete is sufficiently cured the lined floor surface should be inspected for voids by tapping the liners with a rubber mallet. Should any voids be detected, they must be repaired (see page 34).

Finally, the liners are joined by extrusion welding and inspected.

#### **Minimum requirements for the floor plaster:**

- Minimum compressive strength:  $\geq 30\text{MPa}$
- Pebble size: 0-8mm
- Non shrinkage behavior



- Joining and fastening of AGRU CPL at floor sections using steel profiles as supports

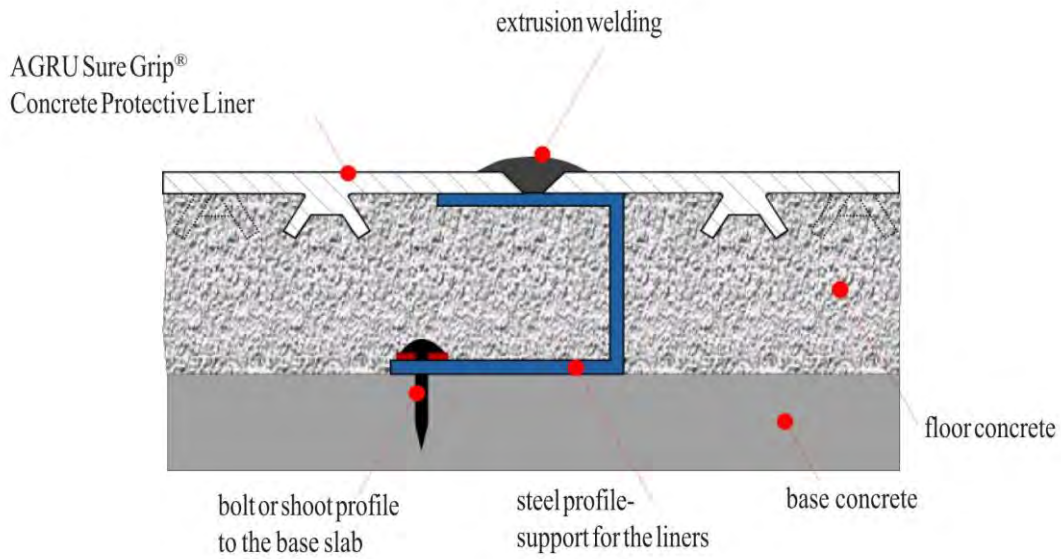

- Floor lining using steel profiles as support – wall/floor transition

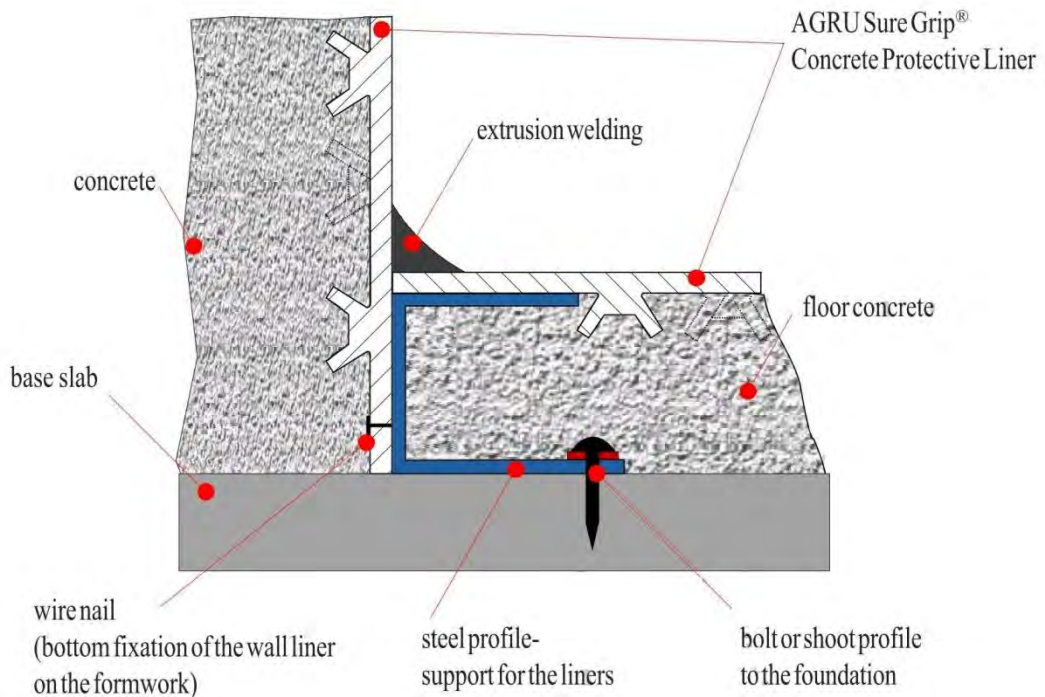

- Floor lining using lean concrete supports

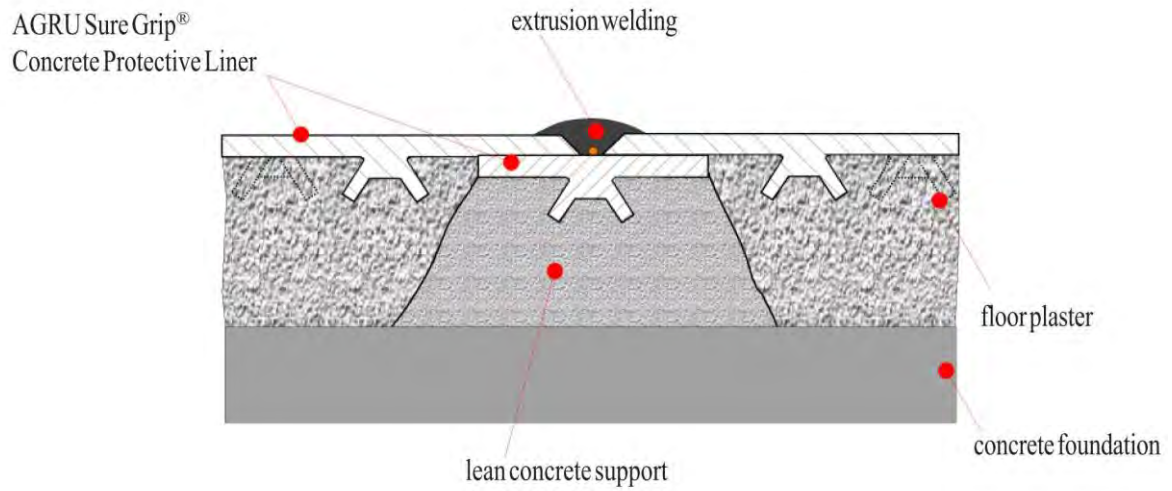

- Floor lining using lean concrete supports – wall/ floor transition

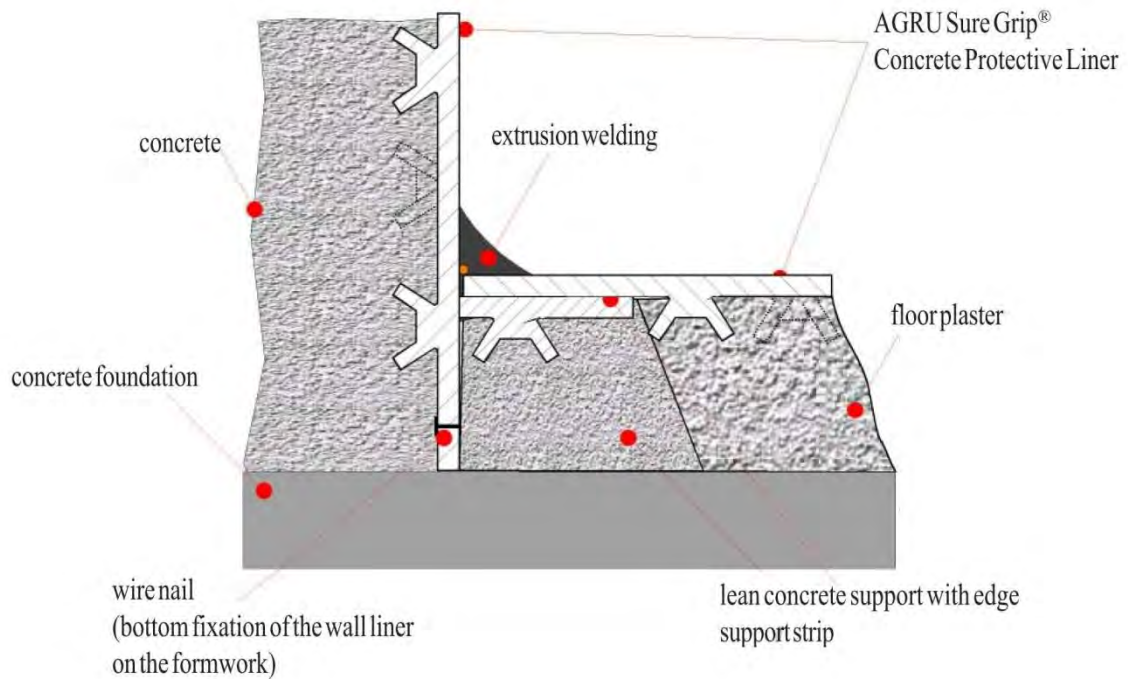



AGRU I-Profiles can also be used as support instead of steel profiles or lean concrete.

- AGRU I-Profile

Property	Standard	Unit	Value
Dimensional stability	DIN 16726	%	≤3
MFR	ISO 1133	%	1,7 – 2,3
Carbon Black Content	DIN EN ISO 11358	%	≥2

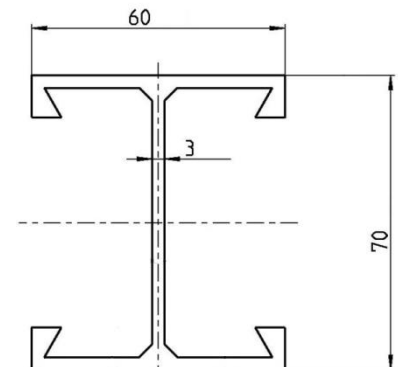

The standard length of the AGRU I-Profile is 4-5m.

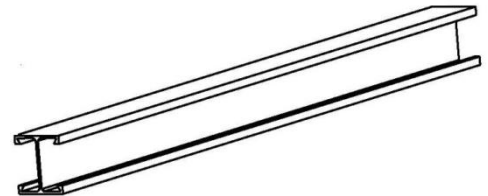

(Example: Floor lining using the AGRU I-Profile)

- Floor standard lining method, for round and rectangular areas

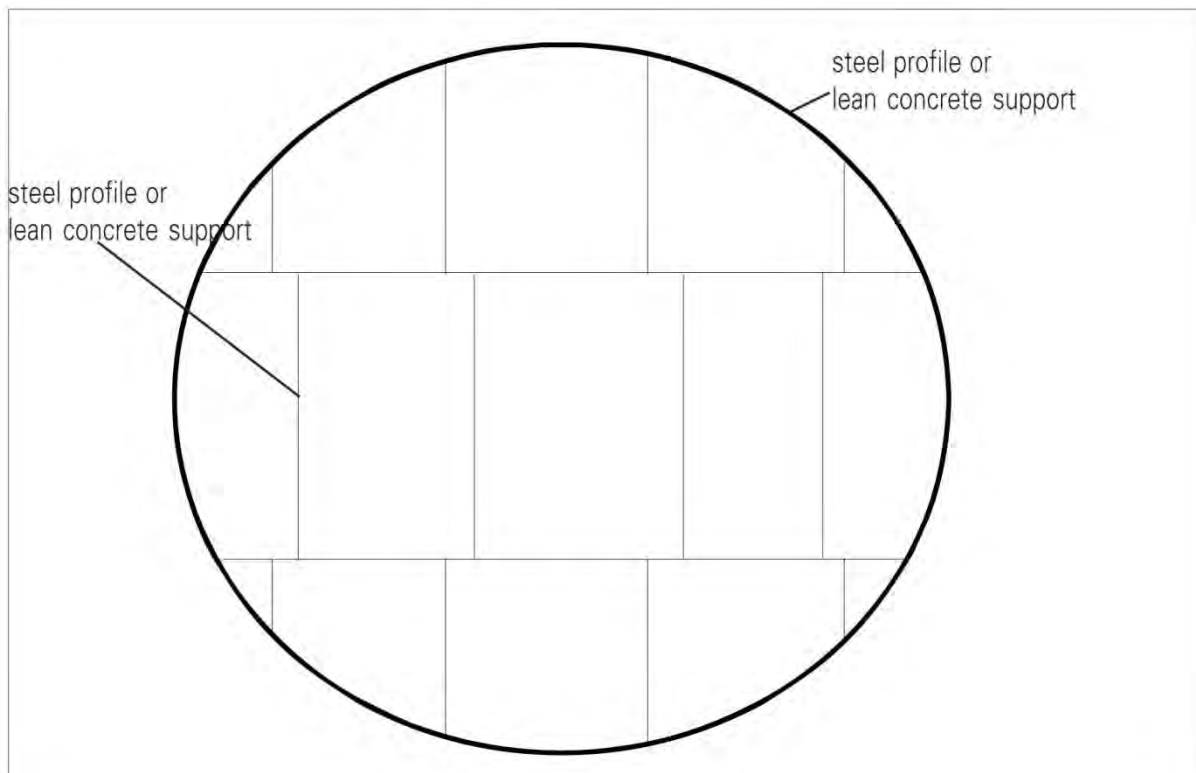

Layout plan of a circular basin floor – Depending on the curvature/ radius of the tank the support for the CPL at the basin perimeter may require lean concrete. In the center or interior portions of the tank steel profiles or AGRU I-Profiles may also be attached to the concrete foundation for use.



Lean concrete supports are installed according to panel size along with a CPL strip (minimum 50mm) and including reinforcement connections for field installation.



After primer-coating (adhesive bonding agent for the floor plaster) is set, the concrete reinforcement is placed and the concrete floor plaster is poured. (Field by field)



The floor plaster is finished at a slightly raised level (2-3mm/ 0.078-0,118in). Next the CPL is laid (rolled) into each field. 'Note that stud rows may have to be removed at the edge area to fit to the profiles.



Important

After laying the CPL into the concrete the CPL panels are entirely covered with wooden boards (plywood) and evenly weighted (weight/m<sup>2</sup>: 30-40kg/ 66-88lb). Bags or plastic buckets filled with water or sand can be used for this purpose. The CPL has to be lightly manually tamped using timers or mechanically vibrated to ensure consolidation and that the concrete plaster fills in behind the CPL anchor studs. The weight must not be removed until the concrete is cured sufficiently.

## 5.2 Grout Injection Method

After the bottom concrete surface (foundation) has cured and been prepared (cleaned with high pressure steam cleaners or sand blasted to remove any residual sludge or other remaining particles), an adhesive coating shall be applied to ensure adequate bonding between the existing foundation and the floor plaster. The requirement for and placement of this adhesive coating shall be as directed by the concrete supplier and/ or the manufacturer of the bonding adhesive. The bottom surface is then divided into fields that match the size of the CPL sheets or fabricated panels.

The maximum size of the area to be depends on the viscosity or “flow ability” of the selected grout as well as its curing time; therefore it is important to perform tests to determine how large of an area can be grouted in one process.

The grouting fields are constructed by attaching perforated steel profiles to the existing concrete (see page 31), thus supporting the AGRU Concrete Protective Liner.

Perforated steel profiles are used to ensure a homogenous bonding of the injector between the individual fields. Alternatively, wire cages may also be used as supports to create these fields. Regardless the supports must be installed along the whole perimeter of the floor section ensuring that the AGRU Concrete Protective Liners are supported at the edges on a bearing surface of at least 20mm/ 0,8inch wide on the steel profiles or the wire cages.

Another option is to use strips of PE with the thickness as the CPL anchor studs. In this case the PE strips need to be perforated as the grout needs to be able to flow through the support strip. The AGRU Concrete Protective Liners are laid onto the profiles or strip, adjusted and joined by extrusion welding.

The field is covered with wooden boards (plywood) across the entire surface and evenly weighted (~400-500kg/m<sup>2</sup> or 80-100 pounds/ft<sup>2</sup>). Bags or plastic buckets filled with water or sand can be used for this purpose.

Subsequently, the grout is injected in the controlled fields till it is pressed out of the aeration pipe. It must be ensured that the aeration pipe provides sufficient ventilation and that the weight loading is not removed until the concrete is sufficiently cured.

Finally the lined floor must be inspected for voids by tapping the liners with a rubber mallet. Should any voids be detected, they must be repaired accordingly (see page 34).

### **Minimum requirements for the grout:**

(Installation procedure in accordance with the grout manufacturer)

- Non shrinking, maximum elasticity, long working time
- Free of gas generating additives
- Mix ratio: specified by manufacturer
- Pebble size: 0/1
- Water-cement ratio: specified by manufacturer

- Joining and fastening of AGRU Concrete Protective liners at floor section by using perforated steel profiles as supports

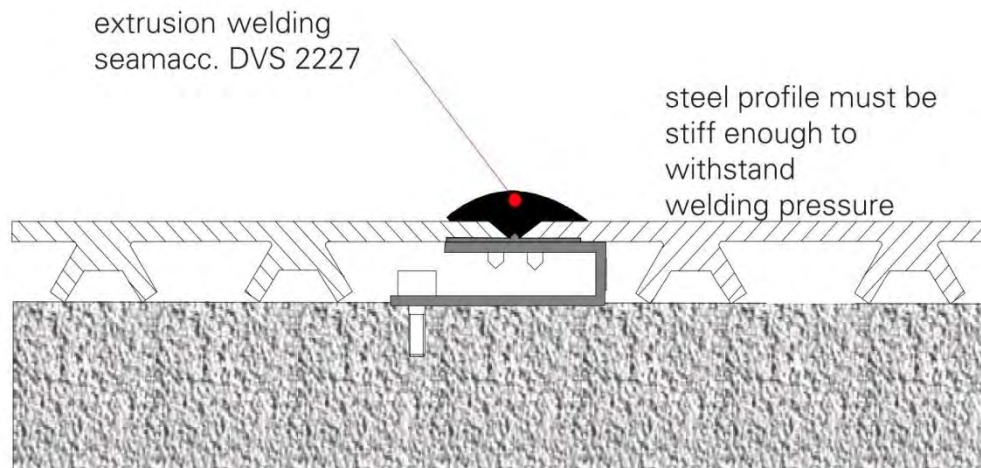
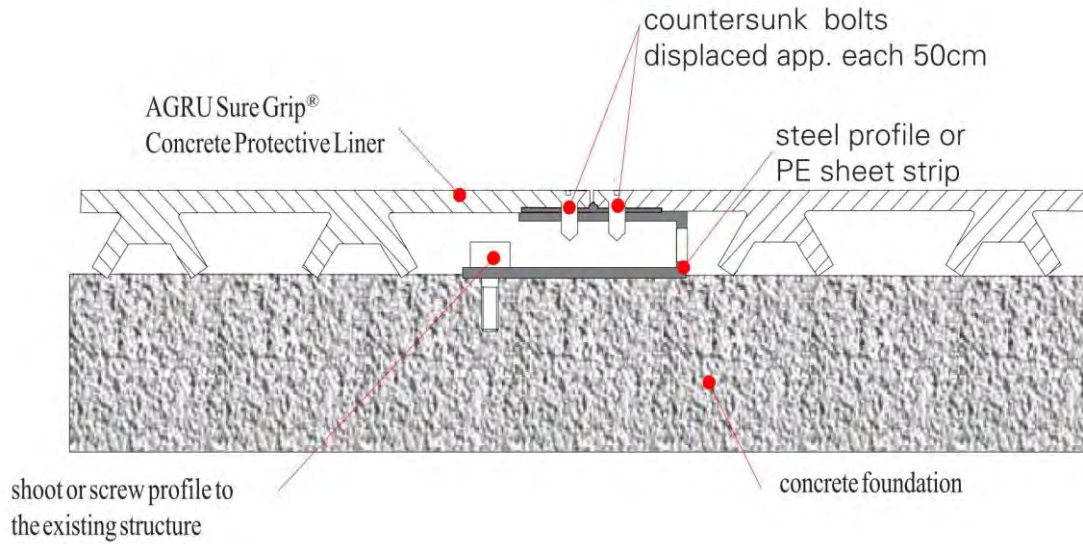

Steel profile or PE-strip (acc. stud height) support for the liners. The distance between the two rows of bolts should enable the welder to cover both screws by extrusion welding.

- Grout injection: AGRU Concrete Protective Liners at floor sections

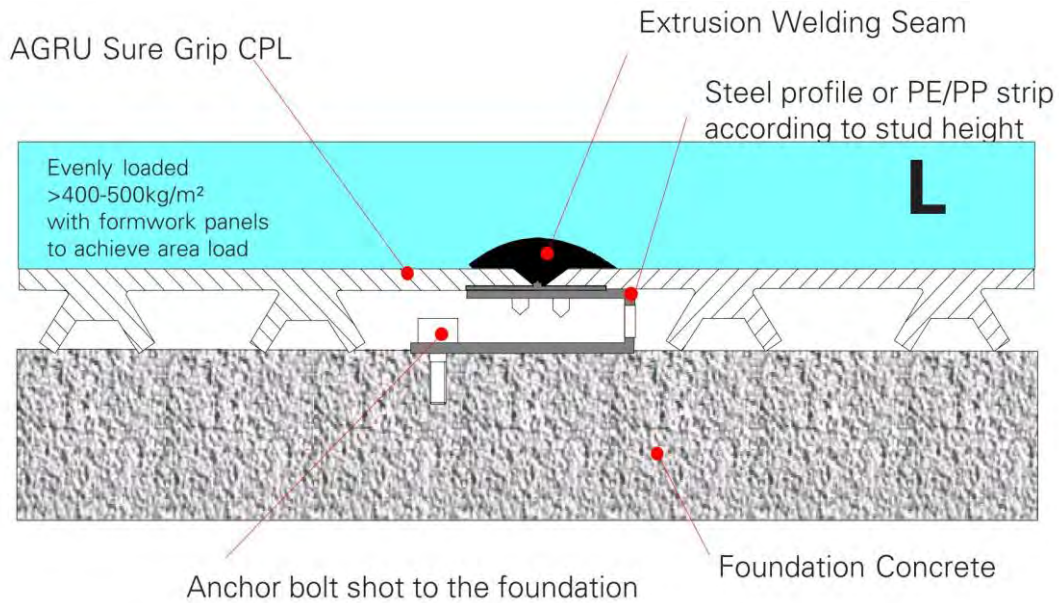

After the extrusion welding seams are tested by means of spark testing, the floor Concrete Protective Liner is supported by a formwork and loaded adequate during the grout injection.

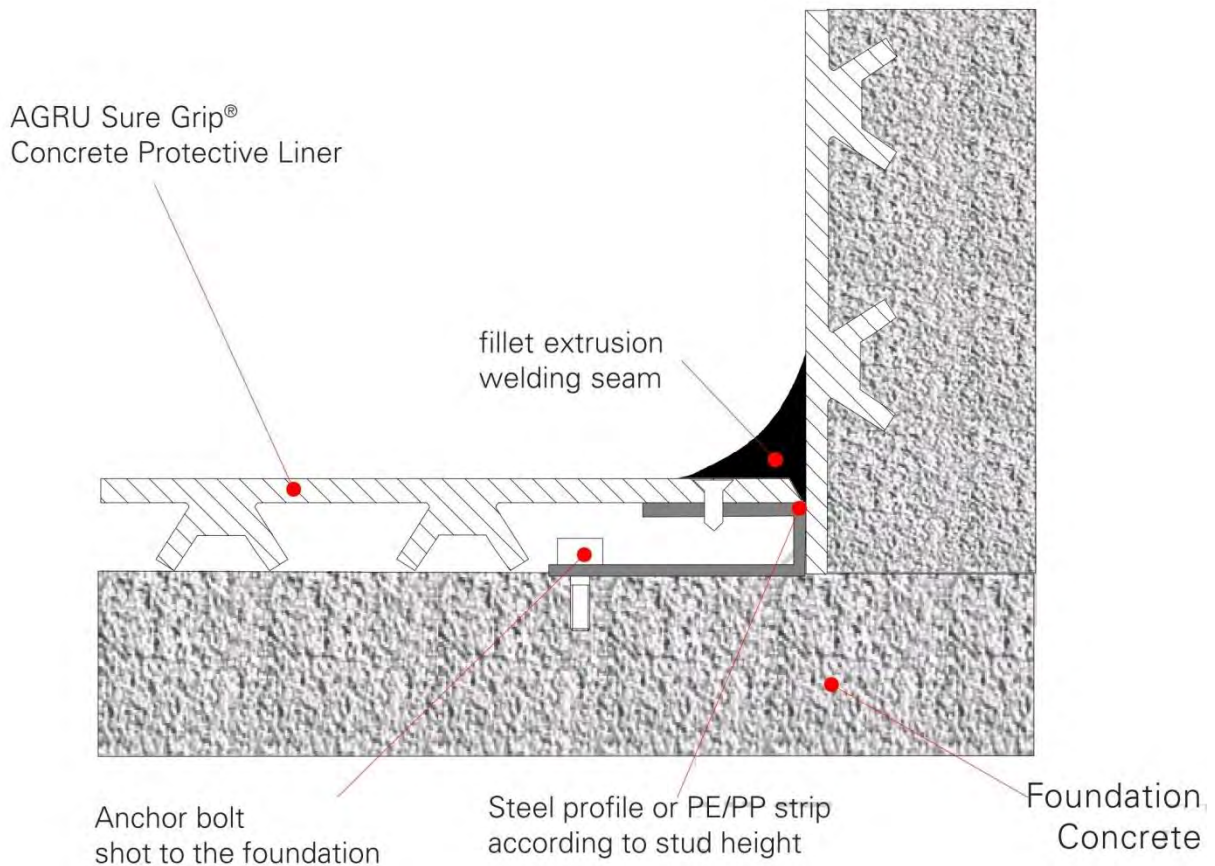



- Starting grout injection

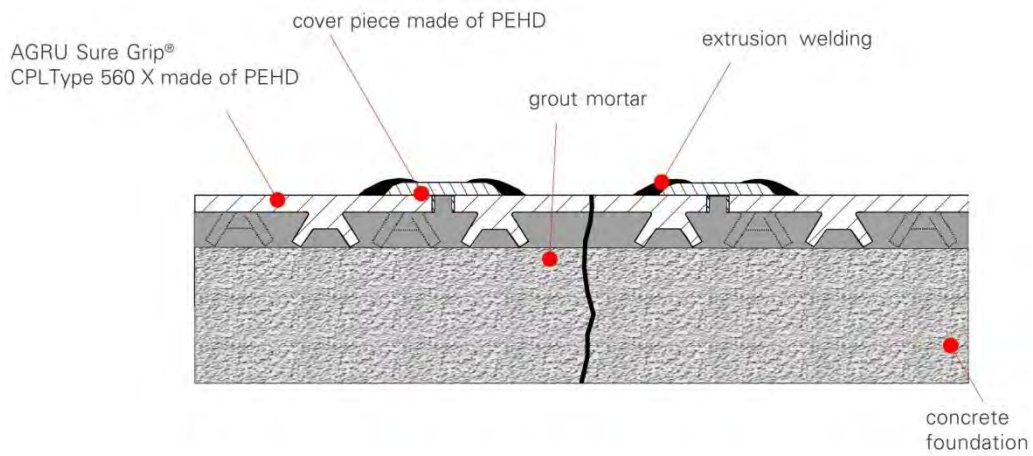
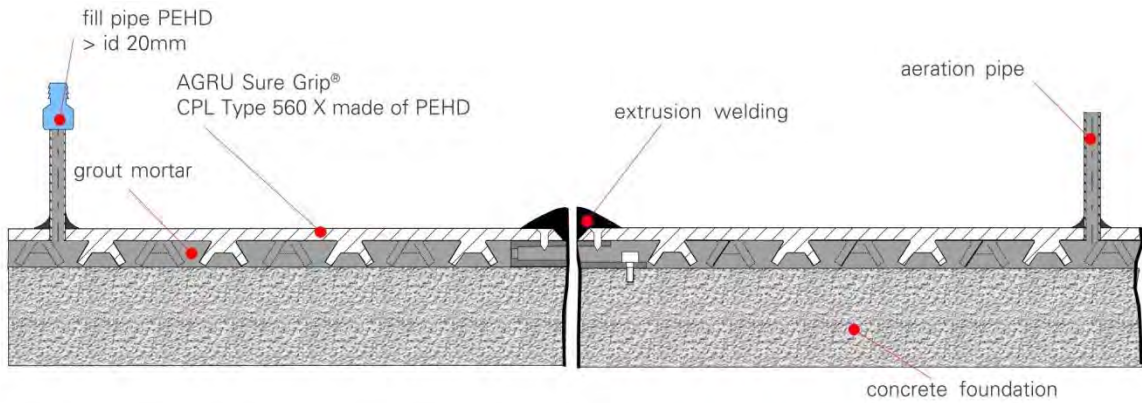
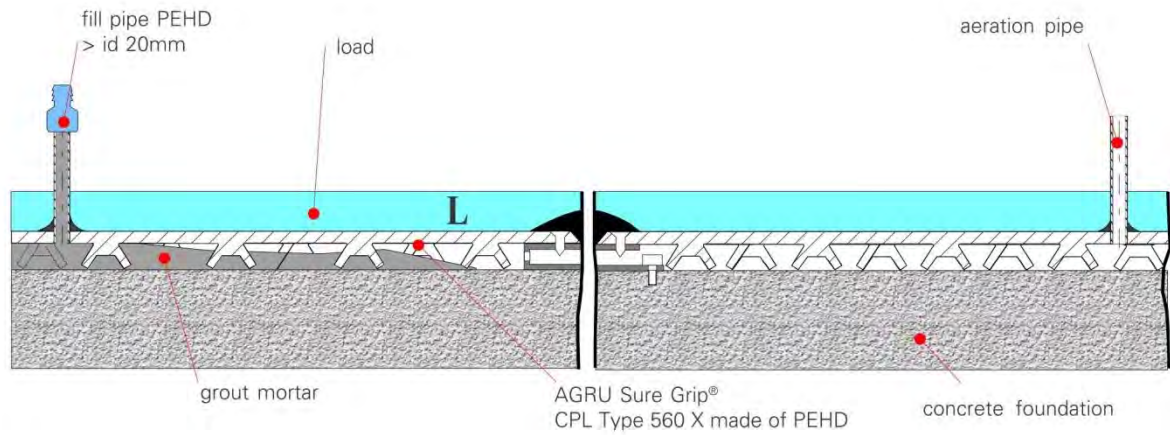

## 6 Filling of Voids in Concrete

If hollow spots are identified by means of tapping the floor lining, two plastic pipes made of the same materials as the liners are installed in the area to be repaired.

After the hollow area is filled with a mortar grout, the pipes are removed and the liner penetrations are patched with smooth liner pieces and extrusion welded to the floor lining.

### Properties of the mortar grout:

- Polyester concrete may be used for small areas (<5dm<sup>3</sup>)
- Otherwise a grout with a compressive strength of at least 80N/mm<sup>2</sup> (11600psi) and less than 1,2% shrinkage can be used

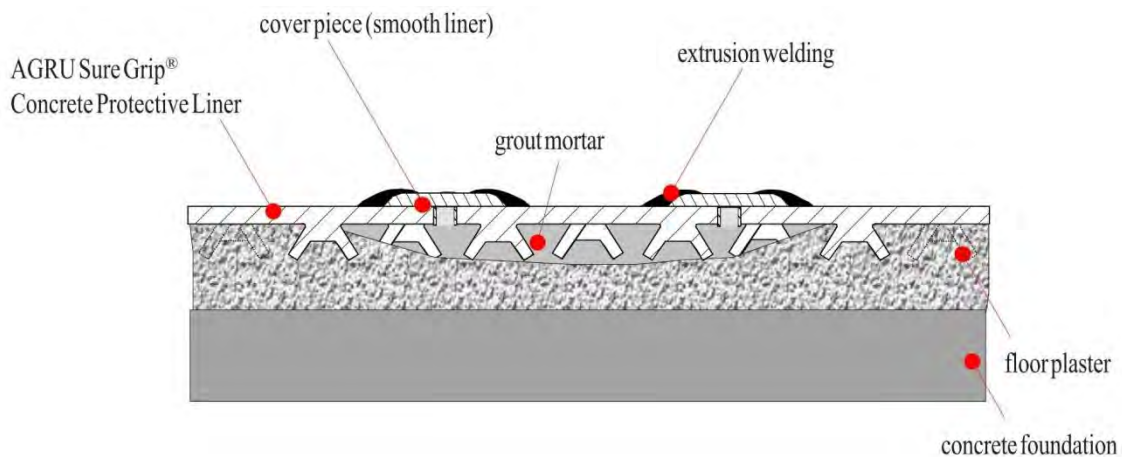
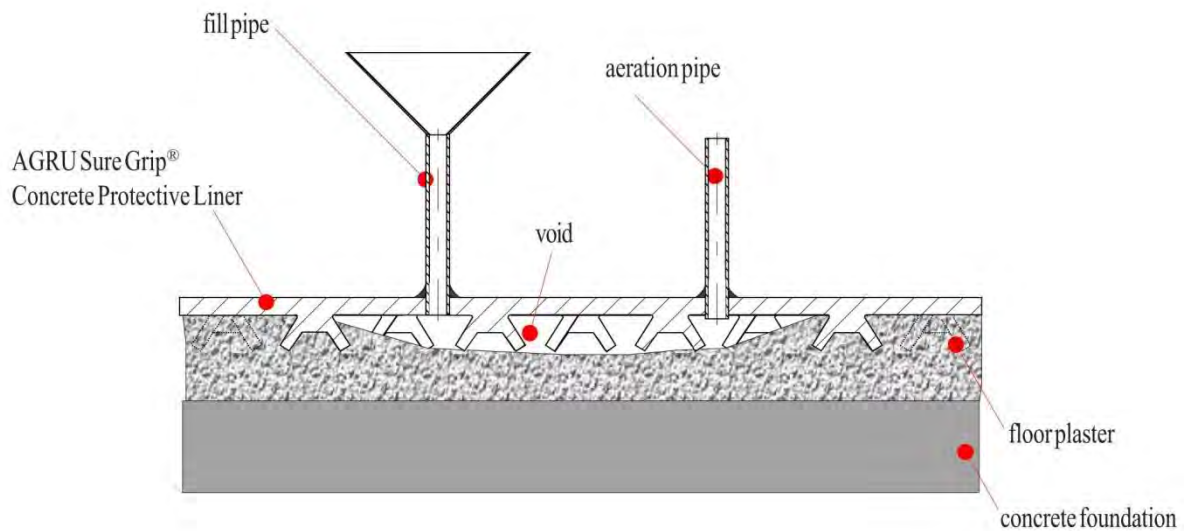

## 7 Wall Penetrations

- Cast-in-Situ

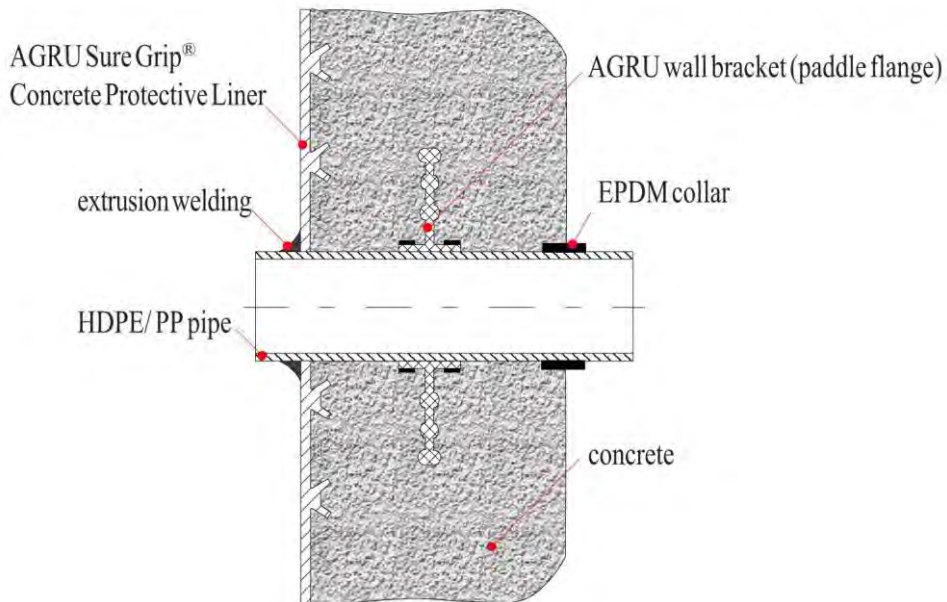

- Retrofit installation by coring removing hole

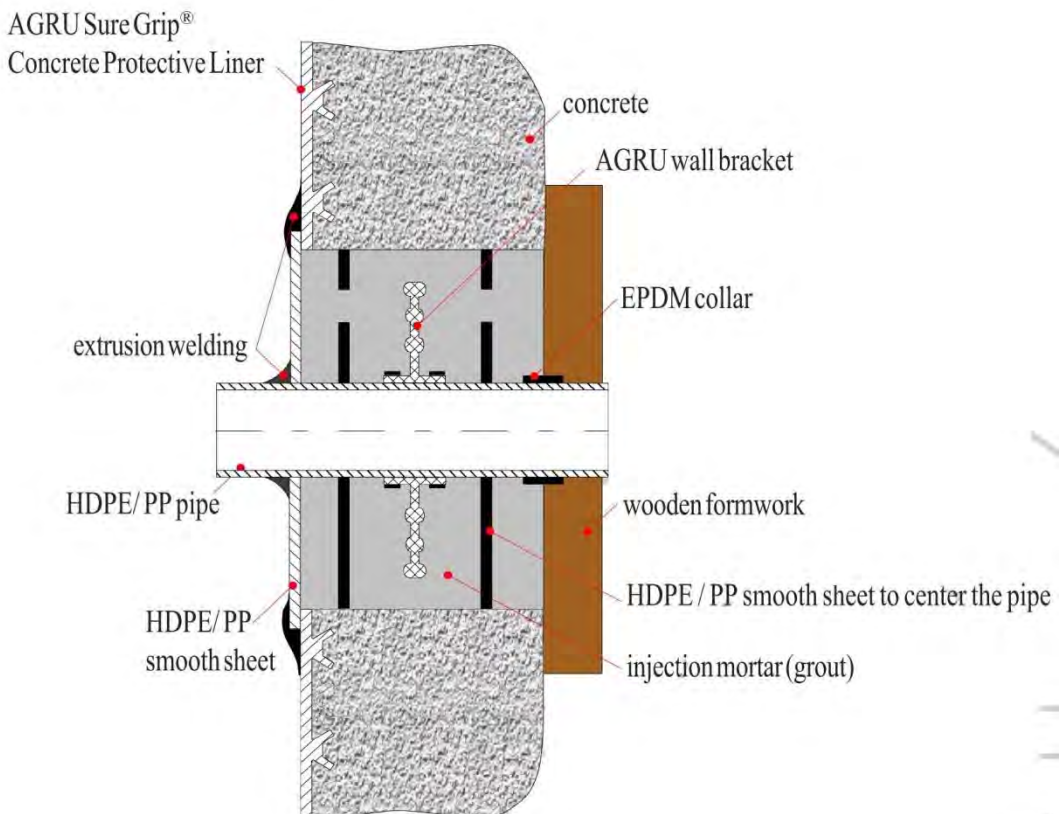

## 8 Welding of joint gaps

The welding of the AGRU Concrete Protective liner must be performed in accordance with the current valid DVS standard (DVS code 2227-1).

**DVS Technical Code 2227-1:** Welding of semi-finished products made of high-density polyethylene (PE-HD) for the sealing of concrete structures in the field or ground water protection and for corrosion protection

## 9 Quality inspection and documentation

Testing of the welding seams of the AGRU Concrete Protective liner must be performed according to the current valid DVS standard (DVS code 2227-1).

Documentation of the welding seams of the AGRU Concrete Protective liner must be performed according to the current valid DVS standard (DVS code 2227-1).

**DVS Technical Code 2227-1:** Welding of semi-finished products made of high-density polyethylene (PE-HD) for the sealing of concrete structures in the field or ground water protection and for corrosion protection